



Right Angle Transfer Module
F-RAT-NX75

Flat-Right Angle Transfer

〈 **User Manual** 〉

For IB-E04F-FT



Read this manual before use

Thank you for purchasing the Right Angle Transfer Module (hereinafter referred to as "this product").



Make sure to read this manual carefully before using, and start using only after you have understood all the product's functions, safety information and precautions.

After reading the manual, make sure to keep it safe in a specified place for future use, whenever necessary.

A PC application "Itoh Configurator E/IP (hereinafter referred to as "ICE")" and its user manual are necessary for IB-E04F-FT setting and programming.
Contact us for the application and user manual.

1. Introduction

Features

Features of this product

- This product is a module to divert at a right angle without changing its level, and there is no impact on the trays.
- All-electric control. No pneumatics, which do not require compressor.

Operation description (when diverting at a right angle)

Load

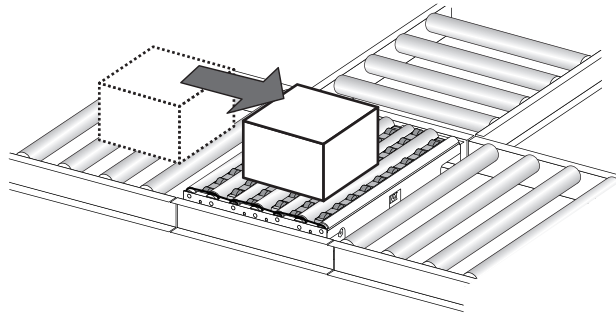

Switch to the diverting
direction

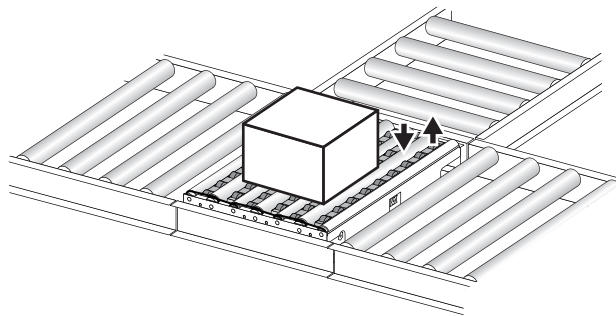

Discharge

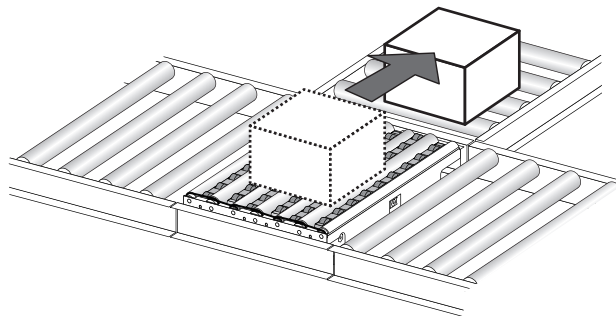

Switch to the straight
direction

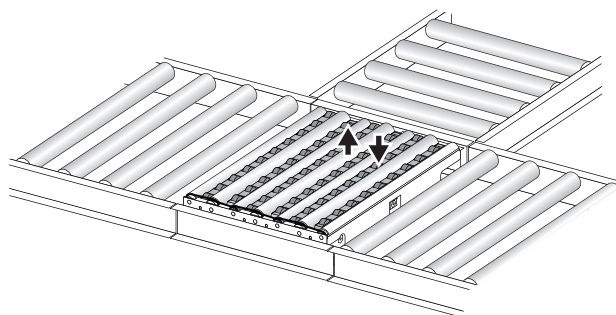

1. Introduction

Disclaimer

This product is designed as a general industrial device. Do not use for other applications. We do not take any responsibility for any damage that may result from the disregarding of these warnings.

Also, in the event that an accident results from the use of this product, we do not compensate for any damage, including abnormalities of equipment, connection devices, and/or software, any damage resulting from malfunctions, and/or any other secondary damage.

Notes on industrial property rights

There are some examples of parts that need to be prepared by customers, as explained within this manual. However, this does not provide any guarantee against the existence of any rights, such as our industrial property rights, or those of other companies, in advance.

Notes on technical support

We respond to technical inquiries based on the contents described within this manual, and on this product within the range of general items for this product unit with standard specifications, and for the options prepared by us.

There are some descriptions in this manual, about parts, equipment, and wiring arranged by customers, as well as the controls and operation under such circumstances. However, these are not included in the guaranteed operating range and/or support.

When in use, please check and perform the aforementioned based on your responsibility according to operation.

About the risk category of this system

This product is intended to comply with the risk category 2*² or lower as defined in EN954-1*¹. It does not comply with purposes beyond risk category 3 or higher.

* 1: European machinery safety standards

* 2: This indicates that even though events that would result in serious injury occur infrequently under assumed risk environment, there is a high probability to avoid danger if you observe the safety contents described in this manual.

About installation environment

This product is not equipped with special dust proof/waterproof countermeasures, and is intended to be used in environments of "Pollution Degree 2"*¹, as defined in IEC60664-1*².

For this reasons, if users install this product in an environment that requires dust proof/waterproof treatments, they need to add necessary countermeasures, and check the performance based on their responsibility.

*1: Insulation coordination for equipment within low-voltage supply systems - Part 1 of the International Standard.

*2: Non-conductive pollution will occur, but it is assumed that condensation will happen to generate conductive property temporarily.

About description of the product

- Depending on the signal type (NPN/PNP) specified by customers, different models of control driver cards are supplied as being the standard for this product.
- In this manual, the driver card model is described as follows: Models are described separately, when needed.

Driver card model		Described in this User Manual
NPN input and output signals	PNP input and output signals	
IB-E04F-N-FT	IB-E04F-P-FT	IB-E04F-FT
HBM-201BN	HBM-201BP	HBM-201

2. Procedures from installation to operation

Procedures from installation to operation

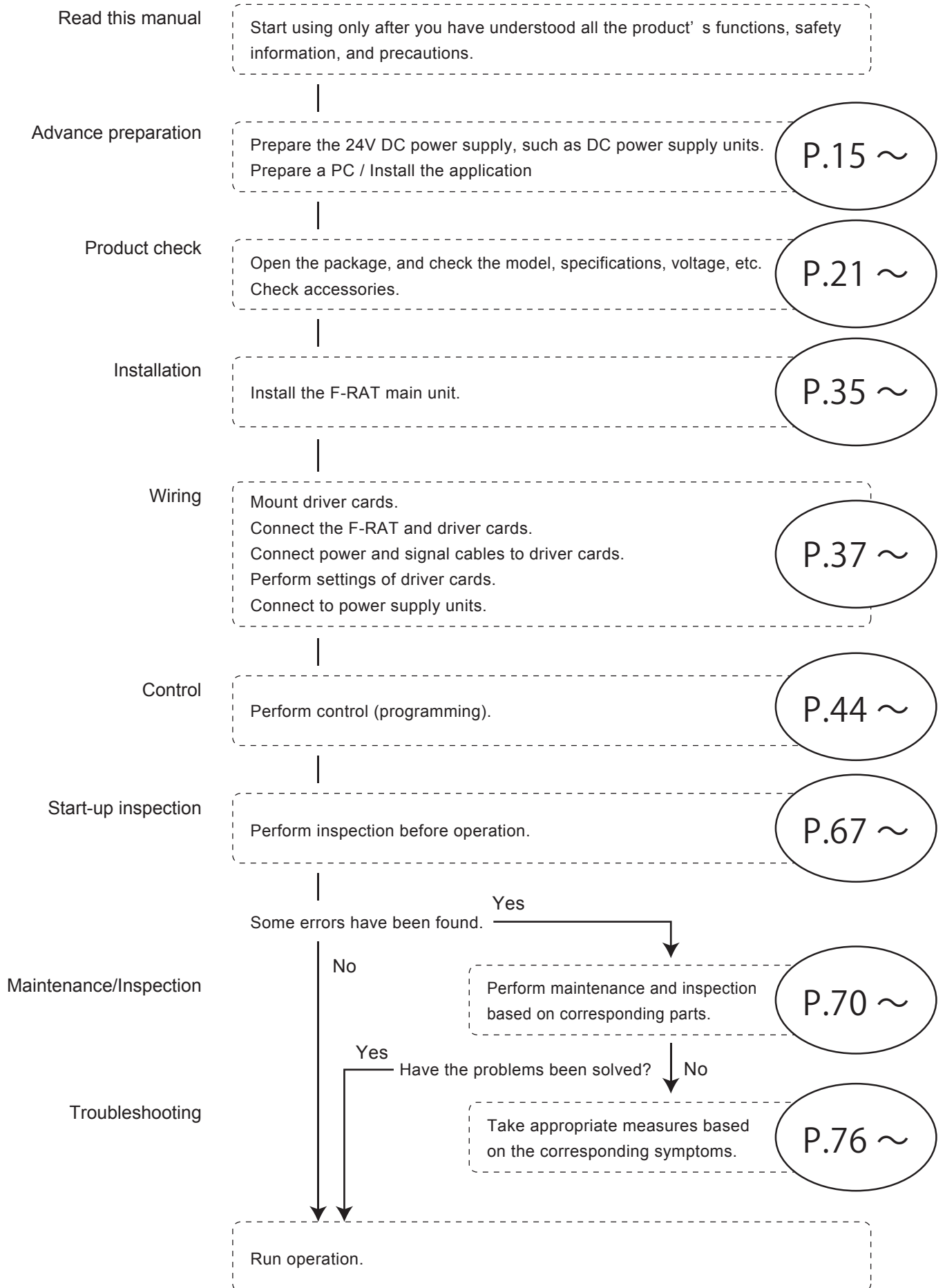

2. Procedures from installation to operation

INDEX

1. Introduction	2
2. Procedures from installation to operation	4
3. Safety precautions	6
3-1. General precautions	8
3-2. Precautions on installation	10
3-3. Precautions on wiring	11
3-4. Precautions related to control	11
3-5. Precautions related to operation	12
3-6. Precautions on maintenance and inspection	12
4. Advance preparation	14
5. Product check	20
6. Structures	23
7. Installation/Wiring	25
7-1. Before installation	26
7-2. Installation	35
7-3. Wiring	37
8. IB-E04F-FT settings	43
8-1. Setting preparation	45
8-2. Property settings	48
9. Control/Operation	52
9-1. Creating the ladder logic	54
9-1-1. Switching the transfer direction	58
9-1-2. Changing the speed	58
9-2. Basic operation	59
9-2-1. Switching the transfer surface	64
9-2-2. About the initial position setting (teaching) of the transfer surface	65
9-3. Program example	66
9-4. What to do before operation	67
10. Maintenance/Inspection	69
10-1. LED indication	70
10-2. Checking and releasing errors	74
10-3. Before replacement work	76
10-4. Replacement of MDR for roller transfer/idlers/roller drive belts	78
10-5. Replacement of the carrier wheel cassette	83
11. Troubleshooting	85
Appendix	89
Appendix 1. Product specifications	90
Appendix 2. Replacement parts/Options	91
Appendix 3. Residual risk list/MAP	94

3. Safety precautions

For parts names in sentences, refer to 6. Structures (P.24).



3-1. General precautions	8
3-2. Precautions on installation	10
3-3. Precautions on wiring	11
3-4. Precautions related to control	11
3-5. Precautions related to operation	12
3-6. Precautions on maintenance and inspection	12

3. Safety precautions

Danger level



To prevent hazards to users and/or others, and/or damage to property in advance, the important precautions to be followed securely is described below.

- The degree of hazard and/or damage that may result if a user disregards the description and operates the product improperly is categorized as the following symbols and explained below.

 WARNING	This indicates a high possibility that severe injury or even death may result.
 CAUTION	This indicates a high possibility that injury, or only property damage may result.

Symbol explanation

- The type of precautions is categorized as the following symbols and explained below.

	This symbol indicates a reminder which users should pay attention to.
	This symbol indicates operations that are prohibited.
	This symbol indicates forced operations that users should always perform.

3. Safety precautions

3-1.

General precautions

WARNING



Do not use the product near places subject to explosive, flammable gas, and/or corrosive atmosphere, and/or combustible materials.

Failure to follow this could result in explosion, fire, electric shock and/or injury.



When using the product in places where serious accidents and/or damage may possibly occur, install backup and/or fail-safe functions systematically.

Failure to follow this could result in the inability to control this product due to driver card malfunction, which could lead to serious accidents.

CAUTION



Do not apply heavy loads to this product, such as stepping on it.

Failure to follow this could result in people falling and/or malfunction.



Do not come into contact with the moving parts, such as the carrier wheels, rollers, or lifting sections, and/or allow clothes to get close to them.

Failure to follow this could result in them getting caught and/or stuck.



Do not forcibly bend and/or pull cables.

Also, do not put heavy materials on cables, or do not get them stuck between cables.

Failure to follow this could result in fire and/or electric shock due to cable damage.



Never remodel the product and/or driver cards.

Failure to follow this could result in serious accidents. We assume no responsibility for remodeled products.



Make sure to attach ground wires to this product and the DC power supply unit.

Failure to follow this could result in electric shock if any malfunction or leakage occurs.



Do not touch the product when it has just stopped operation.

Failure to follow this could result in burns.



Do not put water and/or oil on the product, and do not transfer wet and/or oily trays.

Failure to follow this could result in electric shock, and/or malfunction.



Do not apply strong impact and/or excessive force to the product, such as hitting it with objects, or dropping it. Also, do not use the equipment if strong impact has been applied, and/or if the appearance has become deformed.

Failure to follow this could result in malfunction due to applied impact.

3. Safety precautions

3-1. General precautions

CAUTION



Stop operation when abnormal sound is heard during operation.

Failure to follow this could result in unexpected accidents.



Do not use in a way exceeding the range of the product specifications.

Failure to follow this could result in malfunction, fire, and/or injury.



Turn off the power supply to the product before moving and/or installing the product, and performing maintenance and inspection (excluding those during operation).

Working while the power is on could result in accidents due to unexpected operation.



Observe the safety regulations required for installation locations, and/or products in use.



Securely wire each cable to connection parts.

Improper wiring could result in electric shock and/or malfunction.



Do not turn on/off relays and/or contactors near power cables, signal cables, and/or driver cards.

Failure to follow this could result in malfunction due to noise generation.



LED or Pull-up/Pull-down circuits implemented in the output circuit of control devices could result in unexpected operation.

Carefully check the output circuit.



Turn on the power in order of external control devices, and then the product.

Turn off the power in order of the product, and then external control devices.

Turning on/off the power in the wrong order could result in malfunction.



Do not unplug power and/or signal cables during operation. Also, do not run/stop this product by the power supply. (Use the signal.)

Failure to follow this could result in malfunction.



Do not forcibly rotate the MDR at times other than maintenance and inspection.

Failure to follow this could result in damage to driver cards, and/or their lifetime to be significantly shortened.



Do not turn off the power during transfer (during MDR rotation).

Failure to follow this could result in malfunction.

3. Safety precautions

3-1. General precautions

 CAUTION



Do not turn on the power when trays are unstable.
Failure to follow this could result in injury, accidents, and/or damage due to load collapse.



Make sure to perform the start-up inspection, and check that devices are free from any abnormalities, and that safety equipment functions correctly before using the product.



When disposing of the product, make consigning contracts with licensed industrial waste disposers, and consign the disposal to them.

3-2. Precautions on installation

 WARNING



In principle, have two or more persons work when carrying and/or installing the product as it is a heavy load.

When hoisting this product, never enter the area under the suspended load.



When hoisting, use appropriate hoisting equipment, and pay special attention to prevent the balance of the suspended load from being lost and/or falling. Also, have only qualified workers conduct the operation. Improper hoisting could result in serious accidents.



Do not hoist this product with goods loaded.
Failure to follow this could result in objects falling.

 CAUTION



When handling, wear protective equipment, such as gloves.
Since this product consists in large part of metal, careless handling could result in hands getting injured.



Make sure to use the recommended tightening torque to tighten bolts for installing the F-RAT main unit and/or fastening screws of driver cards.
Failure to follow this could result in bolts and/or screws loosening, and/or malfunction.



Check the corresponding installing direction to the loading/discharging sides before installing.
Failure to follow this could result in objects/body parts getting caught and/or stuck.

Safety precautions

Advance preparation

Product check

Structures

Installation/Wiring

IB-E04F-FT settings

Control/Operation

Maintenance/Inspection

Troubleshooting

Appendix

3. Safety precautions

3-2. Precautions on installation

CAUTION



Take appropriate measures to prevent trays from popping out of the equipment.

For example, mount guide rails on the conveyor frames. Failure to follow this could result in workers getting injured by trays popping out of the equipment.



If necessary warning/caution labels become hidden after installing fences, affix again on places where they can be seen.



Do not change SW401 on IB-E04.
(All switches #1 to #4 are OFF: Factory settings)

3-3. Precautions on wiring

CAUTION



Perform wiring when the power is shut off.

Failure to follow this could result in electric shock and/or accidents due to unexpected operation.



When attaching or removing connectors, turn off the power first, securely hold connectors, and perform operation.

Also, do not apply excessive force to the driver card connection parts, such as obliquely attaching or removing connectors.

Failure to follow this could result in electric shock, malfunction, and/or accidents due to unexpected operation.



Securely attach connectors to the driver card connection parts.

Improper wiring could result in electric shock and/or malfunction.



Perform wiring to connectors so that cables make secure contact with connectors.

Barb lines from the cable core could result in heat generation and/or fire due to changes of contact resistance, and/or short circuit with the adjacent contact.

3-4. Precautions related to control

CAUTION



Do not change switch settings for HBM-201.

Failure to follow this could result in malfunction, and/or accidents due to unexpected operation.



Do not turn the driver card switches with excessive force.

Failure to follow this could result in malfunction.

3. Safety precautions

3-5.

Precautions related to operation

 **CAUTION**

- 

Do not forcibly move trays when they are placed on the carrier wheels.

Failure to follow this could result in damage and/or malfunction.
- 

Make sure to perform the start-up inspection before starting operation.
- 

At the start-up inspection, wear protective equipment, such as gloves.

Failure to follow this could result in hands getting injured by metal parts.
- 

At the start-up inspection, shut off the power, and perform inspection. (excluding inspection to be performed when operating this product.)

Failure to follow this could result in injury due to unexpected operation, such as getting caught and/or stuck.
- 

When operating this product at the start-up inspection, take appropriate measures to prevent fingers from getting stuck and/or caught in carrier wheels and/or rollers.

Also, get ready to shut off the power in the event that something should happen.

Failure to follow this could result in accidents/injury by getting caught and/or stuck.
- 

If any abnormalities are found at the start-up inspection, make sure to take countermeasures before the trial run.

Failure to follow this could result in damage and/or malfunction.

3-6.

Precautions on maintenance and inspection

 **CAUTION**

- 

If any abnormalities are found, do not use this product until the causes have been eliminated completely .

Using this product with unattended abnormalities could result in not only damage to the devices, but also unexpected accidents.
- 

Have specialists (or people who have sufficiently acquired skills) perform maintenance and inspection under instructions by management supervisors.
- 

At the time of repair and replacement work, turn off the power to all connecting devices.

To prevent wraparound for the power circuits and/or signals, shut off the power, wait a sufficient amount of time, and discharge electricity inside the DC power supply equipment.
- 

At the time of maintenance and inspection, post warning labels so as to prevent unauthorized persons from turning on the power.

Failure to follow this could result in malfunction and/or unexpected accidents.

3. Safety precautions

3-6.

Precautions on maintenance and inspection

CAUTION



When repairing/replacing, wear protective equipment, such as gloves.

Failure to follow this could result in hands getting injured by metal parts.



Do not disassemble sections and/or parts other than those specified.

Failure to follow this could result in malfunction and/or unexpected accidents.



Depending on sections and/or parts to be repaired and/or replaced, they need to be rotated and/or lifted by hand.

Pay attention not to get caught and/or stuck. Failure to follow this could result in injury.



Before the trial operation after repair/replacement,

- Check that the roller drive belts have been mounted properly.
- Check that there is no friction between the moving parts, or between the moving and fixed parts.
- Check that screws/covers previously removed have been securely mounted again.
- Check that all parts are installed.

Failure to follow this could result in malfunction and/or unexpected accidents.



Make sure to prepare repair/replacement parts designated by ITOH DENKI.

Using parts other than those designated by ITOH DENKI could result in malfunction.

4. Advance preparation

4. Advance preparation

Wiring image

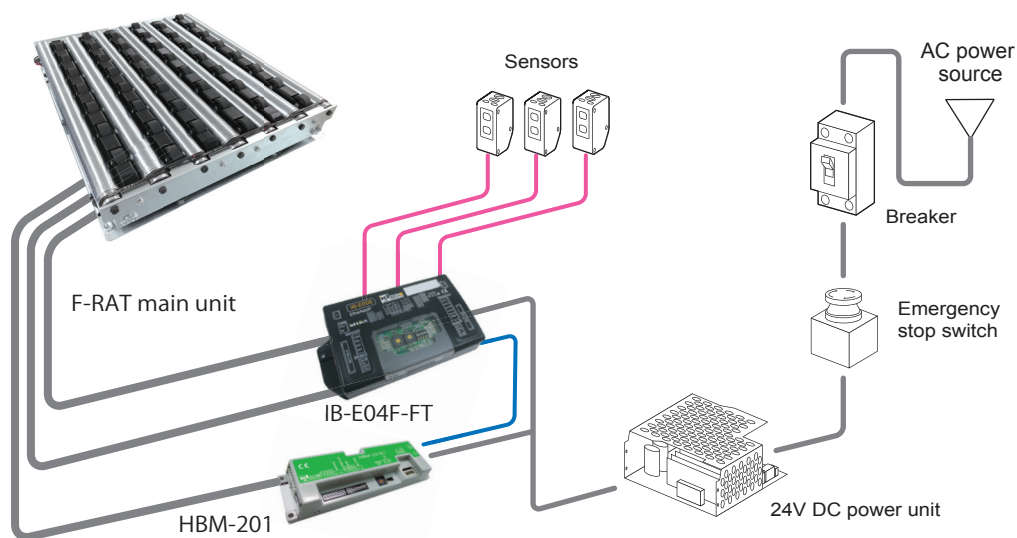

【Important】 As for the sensor input, and input/output signals of driver cards, adopt the number of inputs/outputs based on operation.

Items to be prepared by customers

- ① 24V DC power supply

Before introducing this product, prepare the following devices separately.

Power supply equipment to supply 24V DC to this product

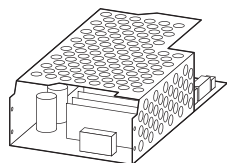

- Switching power supply (24V DC/8A, 192W or more) *
* The power supply should not activate protection with peak current 30A, 1 msec or below.
- 24V DC Battery



Operation

■ Since F-RAT uses MDR for each of carrier wheel transfer, roller transfer, and drive switching (3 MDRs in total), it is not recommended to use multiple MDRs at the same time.



■ A switching power supply is recommended as the DC power supply (24V DC±10%) for drivers.

■ Use a stabilized power supply that has an adequate capacity and does not fluctuate due to load variation.

■ The power supply shall have a capacity larger than the rated value of this product.

■ A transformer type power supply cannot be used.

■ Secure a voltage of 24V DC±10% at the power supply terminal of a driver card.

■ If the capacity of the power supply is less than the rated power of this product, it may cause the supply voltage leading malfunction or damage. Be sure to use the power supply with a capacity larger than the rated power of this product.

■ For the power supply unit, use an isolation type switching power supply compliant with the safety standard (IEC62368-1 or UL62368-1) for Information technology equipment.

4. Advance preparation

② Sensors

Zone sensors to check the tray, and area sensors to check loading and discharging, etc.

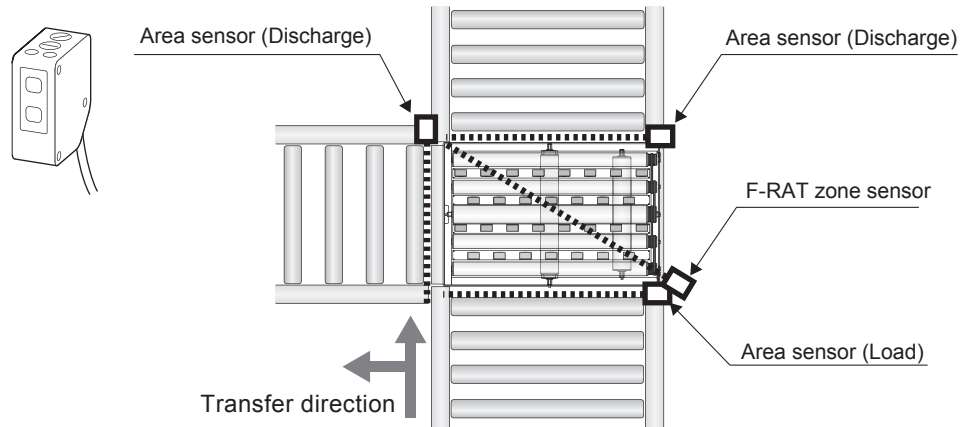

Term

Zone sensor

A sensor to detect the existence of trays within the zone

Area sensor

A sensor to detect load and discharge of trays

③ Wiring materials

Necessary for wiring of power and signal cables to driver cards.

<Available wire diameter for driver card connectors>

Connector \ Driver card	IB-E04F-FT	HBM-201
Power connector	1.25~2.5mm ² (AWG : 16~12)	0.5~1.5mm ² (AWG : 20~14)
Control connector	0.08~0.5mm ² (AWG : 28~20)	



- To select the current capacity of wiring materials, secure a high safety margin based on the current value in the equipment to be used.
- Longer wiring between the power supply unit and driver cards/controllers could cause the voltage to decrease, resulting in malfunction and/or damage.

④ PC

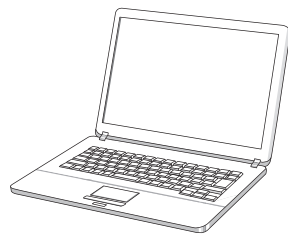

PCs that meet the following requirements

- OS: Microsoft Windows 7 or later
 - CPU: CPU core i5 or higher
 - Memory: 4 GByte or more
 - Framework Ver 4.5 or higher
 - CRT resolution: 1024×768 [XGA]
 - PCs in which data area has to be secured sufficiently
 - Keyboard/Mouse (Touch operation unavailable)
- ※If Framework has not been installed, install Framework Ver.4.5.
 ※If some problems resulting from other factors have been found, it is possible we cannot address them in the specifications, depending on the contents. We appreciate your understanding.

⑤ LAN cable

Category 5e or more

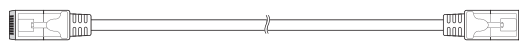

4. Advance preparation

⑥ Application

Installing the designated application

A PC application “ICE” and its user manual are necessary for IB-E04F-FT setting and programming.

Contact us for the application and user manual.



- Use ICE Ver1.1.4.0 or later.
IB-E04F-FT cannot be used with the version released before ICE Ver 1.1.4.0.
- Illustrations and/or procedures shown below may partly differ depending on your PC. In such cases, perform settings and operations to ensure the application will be safely installed of your own accord, and under your own responsibility.

1 Start the ICE setup program.

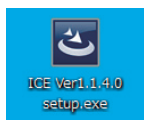

2 Proceed to the installation according to the instructions on the screen.

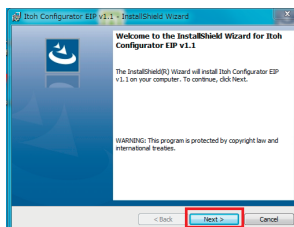

Click

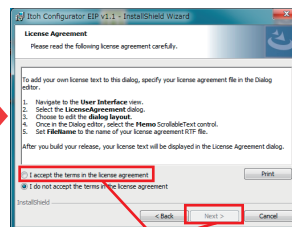

Accept the license agreement articles, and click

3 Click to start installation

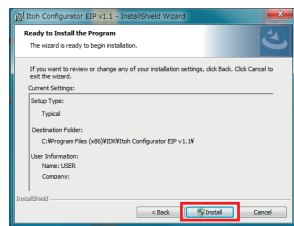

Click

※When the following screen is displayed during installation, click “Yes”.

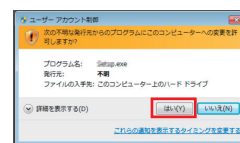

4 When installation is complete, the ICE icon will be displayed on the PC's desktop.

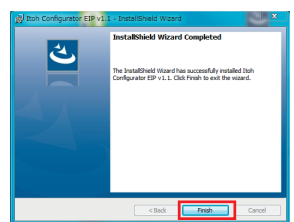

Click



⑦ MDR extension cable (option)

Necessary when the installing location of the F-RAT main unit is far from that of the driver cards.

■ 12P extension cable : F-RAT [M1 / M2] — IB-E04F-FT [MA]

Model	12P extension cable length
ACE-CBM-G0600	L= 600mm
ACE-CBM-G1200	L=1200mm

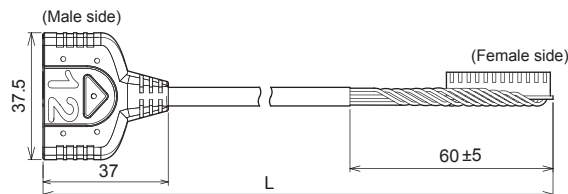

■ 10P extension cable : F-RAT [M3] — HBM-201

Model	10P extension cable length
ACE-CBM-A0600	L= 600mm
ACE-CBM-A0850	L= 850mm
ACE-CBM-A1200	L=1200mm

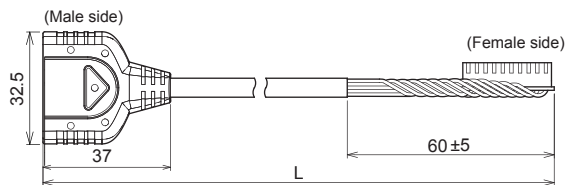

- Use extension cables of 1200 mm or less.
- Securely insert each connector part.

4. Advance preparation

⑧ Stay (option)

Size	L	X	(mm)
6040 / 7540 / 9040	370	400	
6050 / 7550 / 9050	470	500	
6060 / 7560 / 9060	570	600	
6070 / 7570 / 9070	670	700	
6080 / 7580 / 9080	770	800	

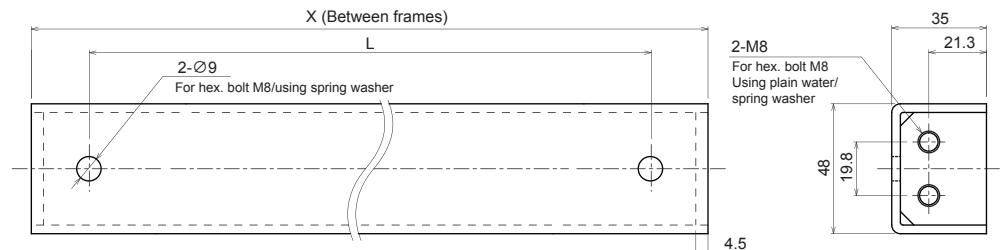

* For X dimensions (between frames) other than those mentioned above, contact us.

⑩ Emergency stop equipment



This product does not include the emergency stop equipment. Customers must make sure to install it.

Install the emergency stop equipment on the side of the DC power supply unit to which the power is supplied.

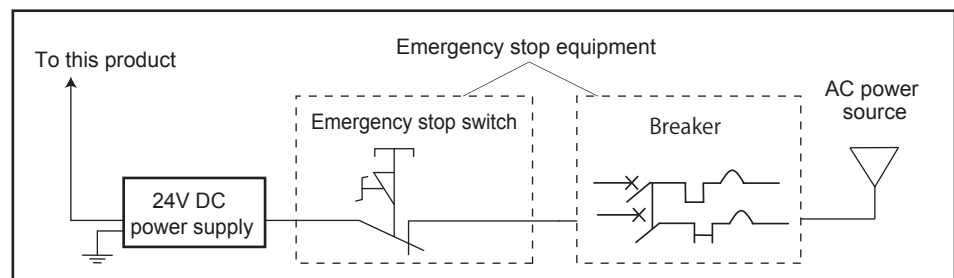

⑩-1 Checking the breaker

Regarding facilities where this product is incorporated, check that a breaker with appropriate capacity for the 24V DC power supply unit has been installed. If abnormal operation should occur, protection through the breaker could be effective.

Note that when using an earth leakage breaker, select one that is "inverter corresponding". Some inverter non-corresponding earth leakage breakers could result in malfunction, since they may recognize high-frequency components of the switching power supply as leakage.

⑩-2 Operation check

When the 24V DC power supply unit has been incorporated, check that the breaker and emergency stop switch can work properly. Perform operation following the trial operation after checking them.

- ① Input to the DC power supply (single phase 100V/200V) is securely turned ON/OFF when turning ON/OFF the breaker.
- ② Input to this product (24V DC) is securely turned ON/OFF when turning ON/OFF the emergency stop switch.

4. Advance preparation

⑪ About the wiring method

⑪-1 When overcurrent protection devices are required

When overcurrent protection devices need to be installed to the DC power supply, some power supplies that need to conform to the safety standards (UL60950-1, etc.) require installation of the specified overcurrent protection device based on their specifications. In such cases, make sure to install the specified overcurrent protection device as described in the figure below. When overcurrent protection devices are not required in the DC power supply specifications, they do not need to be installed.

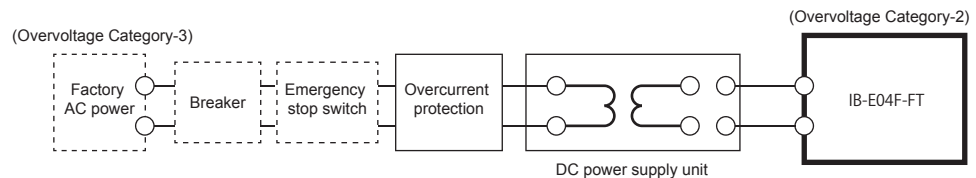

⑪-2 Adding the MDR power shutdown circuit in the event of a failure

In the event that a failure occurs, such as overload or abnormal temperature, the driver card will transmit the data of failure generation to external devices via the Ethernet communications, as well as stopping the drive operation. However, it does not have the MDR power shutdown function. Accordingly, if the MDR power needs to be shut down in the event of a failure, as described in SW1 of the figure below, add the power shutdown circuit using a PC or PLC, and shut down the power from these devices in the event of a failure.

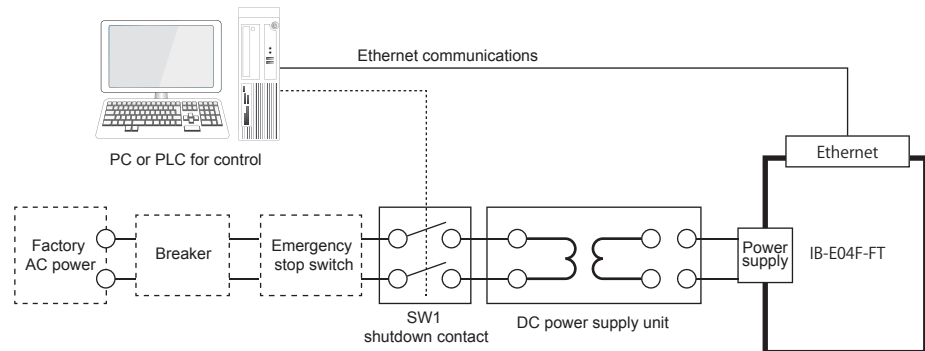

■ At the time of power shutdown, not only the MDR power, but also the IB-E04F-FT control power will be shut down.

5. Product check

5. Product check

Checking the model

Unpack the product, and check that the product model is as ordered.

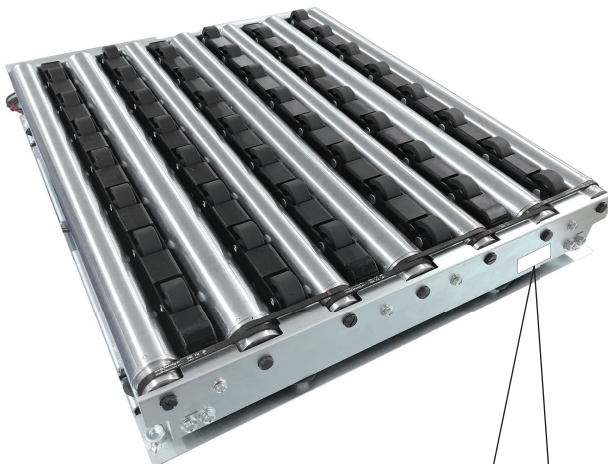

< Product label details >

Model →

FLAT RIGHT ANGLE TRANSFER F-RAT-NX75-F60-7540-EN-S3 RATED INPUT: DC24V / 4.9A RATED POWER: 56W PAYLOAD: max 50 kg SERIAL No: MFG. YEAR: DOC:

Checking appearance

- ① Check that the main unit is free from any abnormalities, such as traces of scratches, dents, dirt, and/or corrosion (rust).
 - ② Check that there is no omission and/or looseness of screws, etc.
- * If any abnormalities are found, contact the supplier immediately.

5. Product check

Checking accessories

Driver card •
Conversion cable

Check that all the following items are included.

Depending on the F-RAT input and output signal type, driver cards with the NPN (N) or PNP (P) signal input are included. (Not included when no driver card has not been specified.)

For F-RAT-NX75-□□□-□□□□-EN-S3

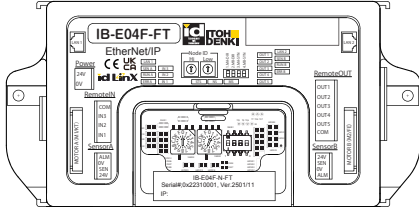

Driver card IB-E04F-N-FT ×1
〈 For carrier wheel / roller transfer 〉

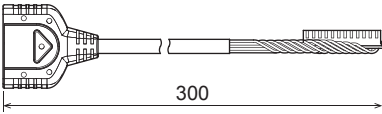

10P/12P conversion cable ×1
ACT-IBE-C0300

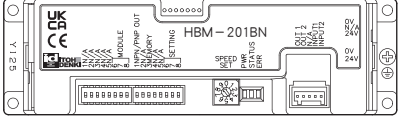

Driver card HBM-201BN ×1
〈 For drive switching 〉

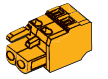

Power connector WAGO231-302/026-000 ×1



Sensor connector WAGO733-104 ×2

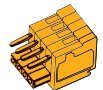

Remote input connector WAGO734-204 ×1



Remote output connector WAGO734-206 ×1



Cross-recessed pan head screw M4 × 10 ×2



Spring washer M4 ×2



Hex. nut M4 ×2

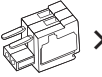

Power connector EAHB05 ×1



Control connector
〈 For HBM-201 〉 ×1



Cross-recessed head SW screw M4 × 15 ×4



Hex. nut M4 ×4

For F-RAT-NX75-□□□-□□□□-EP-S3

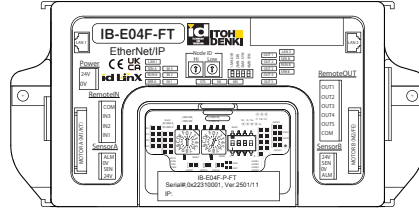

Driver card IB-E04F-P-FT ×1
〈 For carrier wheel / roller transfer 〉

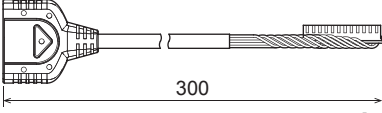

10P/12P conversion cable ×1
ACT-IBE-C0300

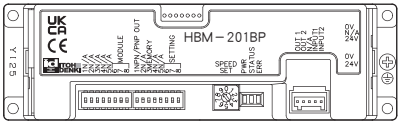

Driver card HBM-201BP ×1
〈 For drive switching 〉

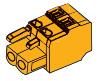

Power connector WAGO231-302/026-000 ×1



Sensor connector WAGO733-104 ×2

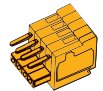

Remote input connector WAGO734-204 ×1

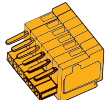

Remote output connector WAGO734-206 ×1



Cross-recessed pan head screw M4 × 10 ×2



Spring washer M4 ×2



Hex. nut M4 ×2

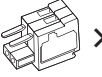

Power connector EAHB05 ×1

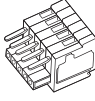

Control connector
〈 For HBM-201 〉 ×1



Cross-recessed head SW screw M4 × 15 ×4



Hex. nut M4 ×4

For installing the F-RAT main unit



×4

Hex. bolt with spring lock and plain washers M8 x 20

Safety precautions

Advance preparation

Product check

Structures

Installation/Wiring

IB-E04F-FT settings

Control/Operation

Maintenance/Inspection

Troubleshooting

Appendix

6. Structures

6. Structures

Structures

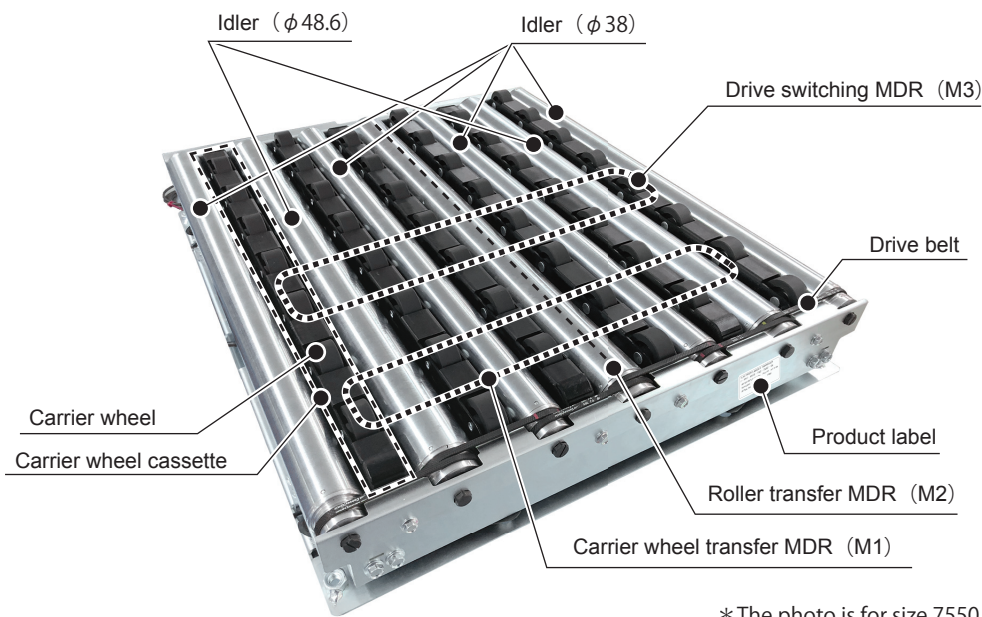

*The photo is for size 7550.

Product designation

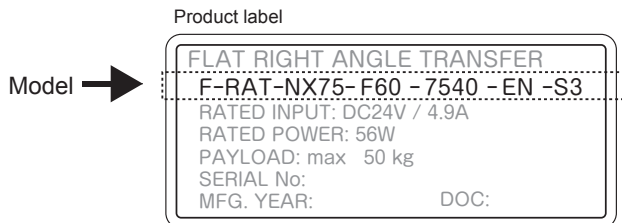

F-RAT-NX75-F60-7540-EN-S3

- ① Motor specifications
 - F ... FE 10P connector type
- ② Nominal speed
 - 17 ... Nominal speed 17m/min type
 - 60 ... Nominal speed 60m/min type
 - * For details, refer to 9-1-2. Changing the transfer speed (P.58).
- ③ Size (L direction)
 - 60 (L595mm)
 - 75 (L745mm)
 - 90 (L895mm)
- ④ Size (W direction)
 - 40 (W395mm)
 - 50 (W495mm)
 - 60 (W595mm)
 - 70 (W695mm)
 - 80 (W795mm)
- ⑤ Included driver cards
 - C ... Standard driver cards (CBK-109 / CB-016 / HBM-201)
 - E ... Driver cards to support network communications (IB-E04F-FT / HBM-201)
 - * Becomes blank when no driver card has been specified.
- ⑥ Input and output signal type
 - N ... NPN (Included with driver cards only for input and output)
 - P ... PNP (Included with driver cards only for input and output)
 - * Becomes blank when no driver card has been specified.

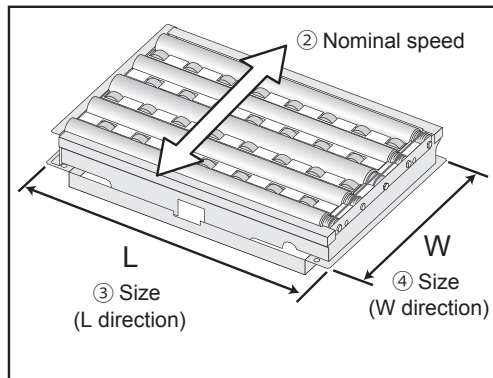

Nominal speed

The speed on the MDR roller surface (m/min), and the nominal speed with a nice round value for convenience. Values differ slightly from the actual speed.

Term

Safety precautions

Advance preparation

Product check

Structures

Installation/Wiring

IB-E04F-FT settings

Control/Operation

Maintenance/Inspection

Troubleshooting

Appendix

7. Installation/Wiring

7-1. Before installation	26
7-2. Installation	35
7-3. Wiring	37

7. Installation/Wiring

7-1.

Before installation

- Prepare stands, and perform frame processing in advance by reference to the mounting holes in dimensions.
- Determine the mounting location for zone sensors to check the existence of trays, and area sensors to check loading and discharging. Then, prepare for them to be mounted.

Mounting preparation for the F-RAT main unit

Size 6040
L595mm×W395mm

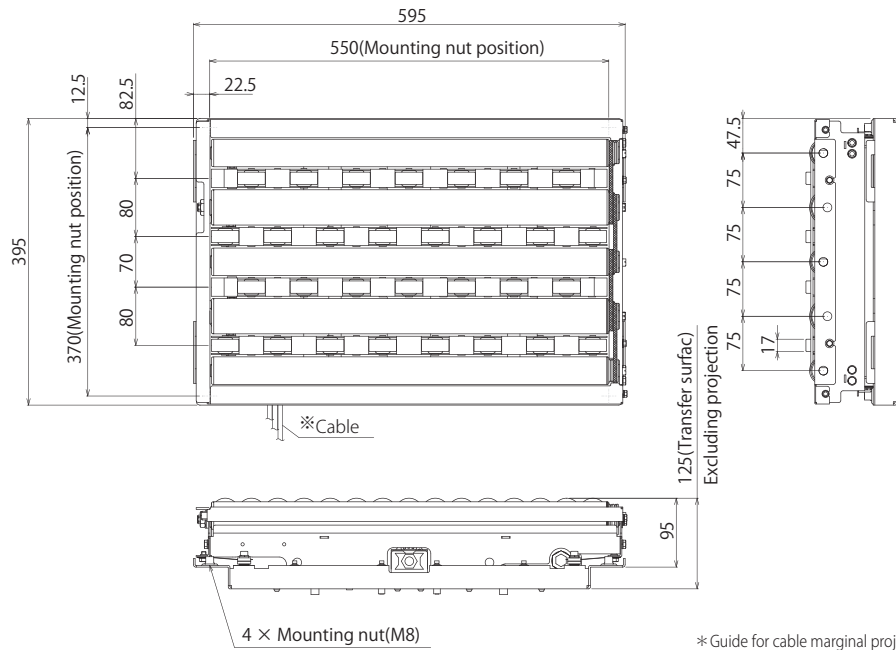

* Guide for cable marginal projecting length (mm)

M1 : Carrier wheel transfer MDR	1000
M2 : Roller transfer MDR	1100
M3 : Drive switching MDR	1300

Size 6050
L595mm×W495mm

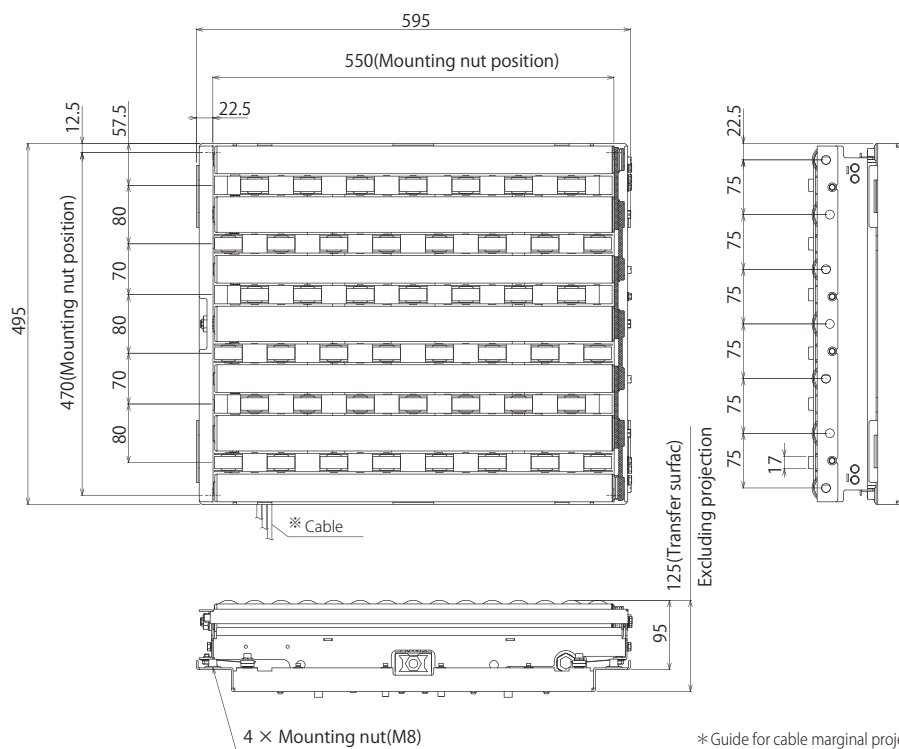

* Guide for cable marginal projecting length (mm)

M1 : Carrier wheel transfer MDR	1000
M2 : Roller transfer MDR	1000
M3 : Drive switching MDR	1300

7. Installation/Wiring

Size 6060
L595mm×W595mm

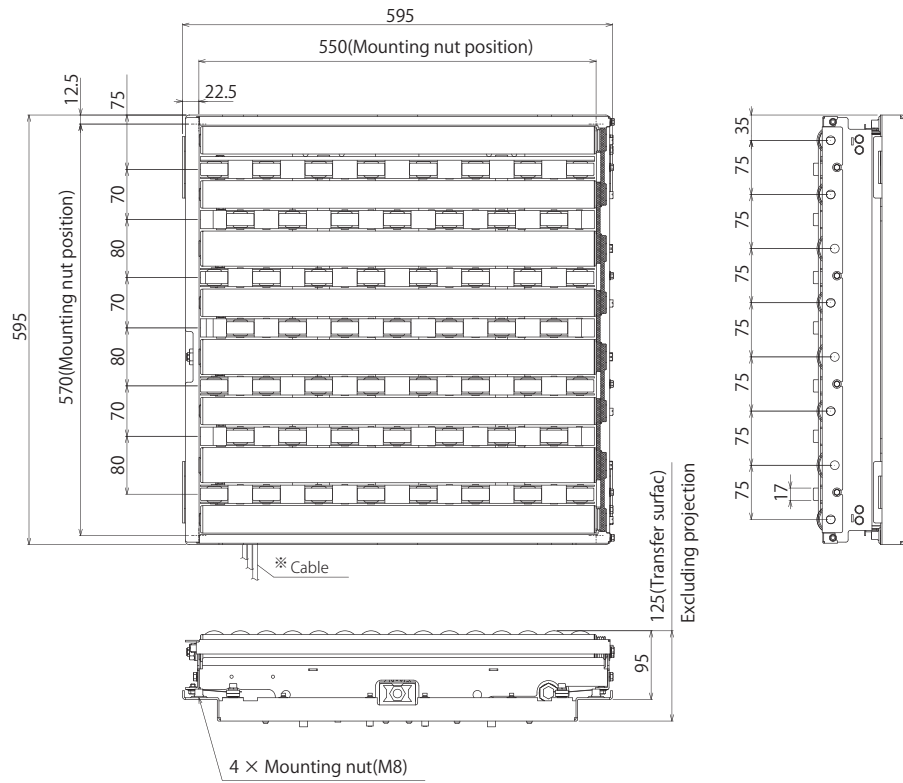

* Guide for cable marginal projecting length (mm)

M1 : Carrier wheel transfer MDR	1000
M2 : Roller transfer MDR	900
M3 : Drive switching MDR	1300

Size 6070
L595mm×W695mm

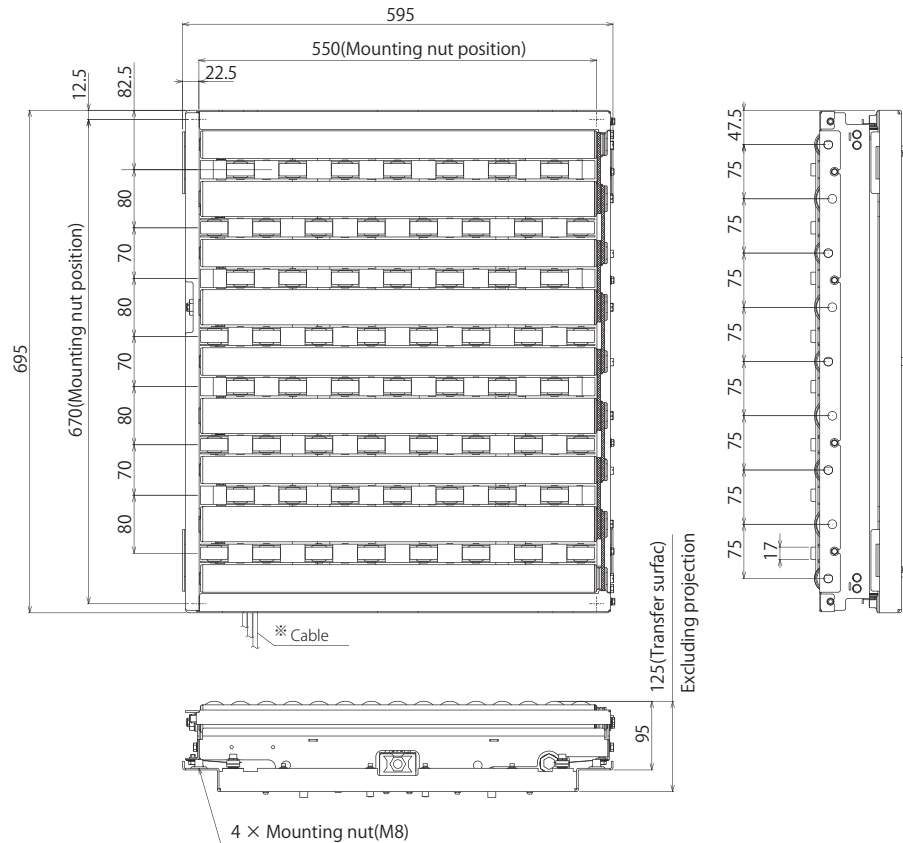

* Guide for cable marginal projecting length (mm)

M1 : Carrier wheel transfer MDR	1000
M2 : Roller transfer MDR	800
M3 : Drive switching MDR	1300

7. Installation/Wiring

Size 6080
L595mm×W795mm

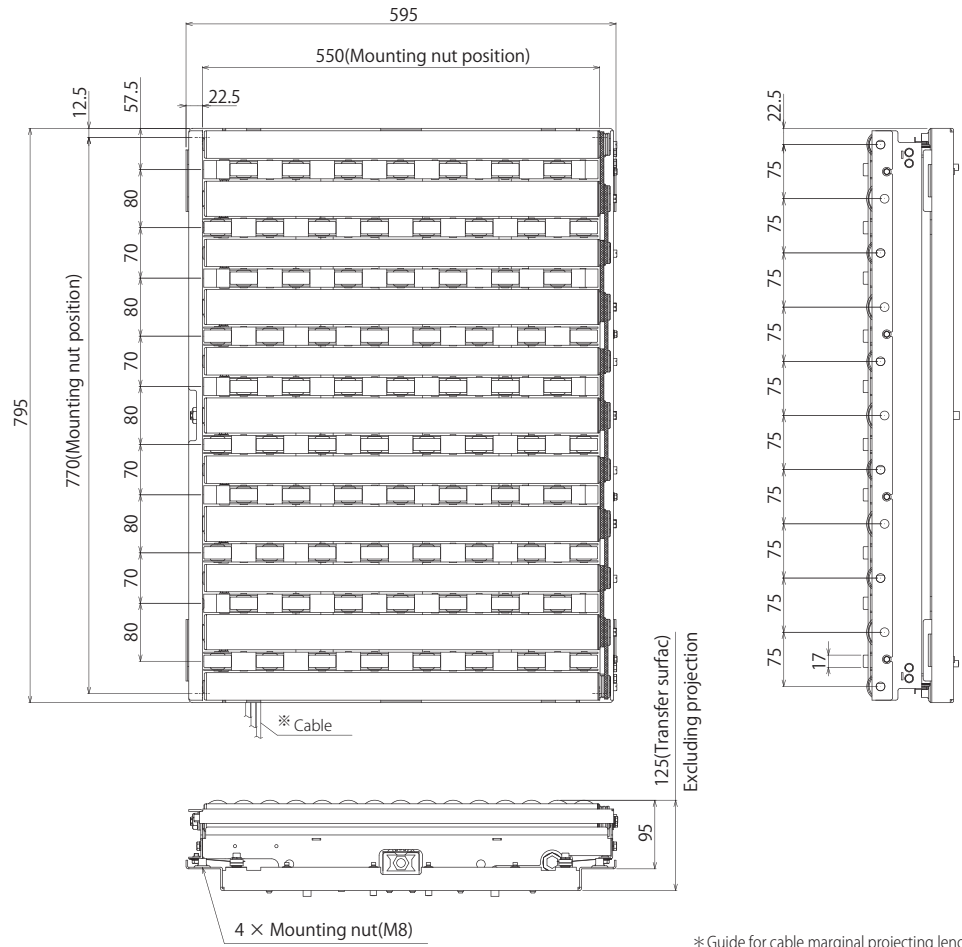

* Guide for cable marginal projecting length (mm)

M1 : Carrier wheel transfer MDR	1000
M2 : Roller transfer MDR	700
M3 : Drive switching MDR	1300

Size 7540
L745mm×W395mm

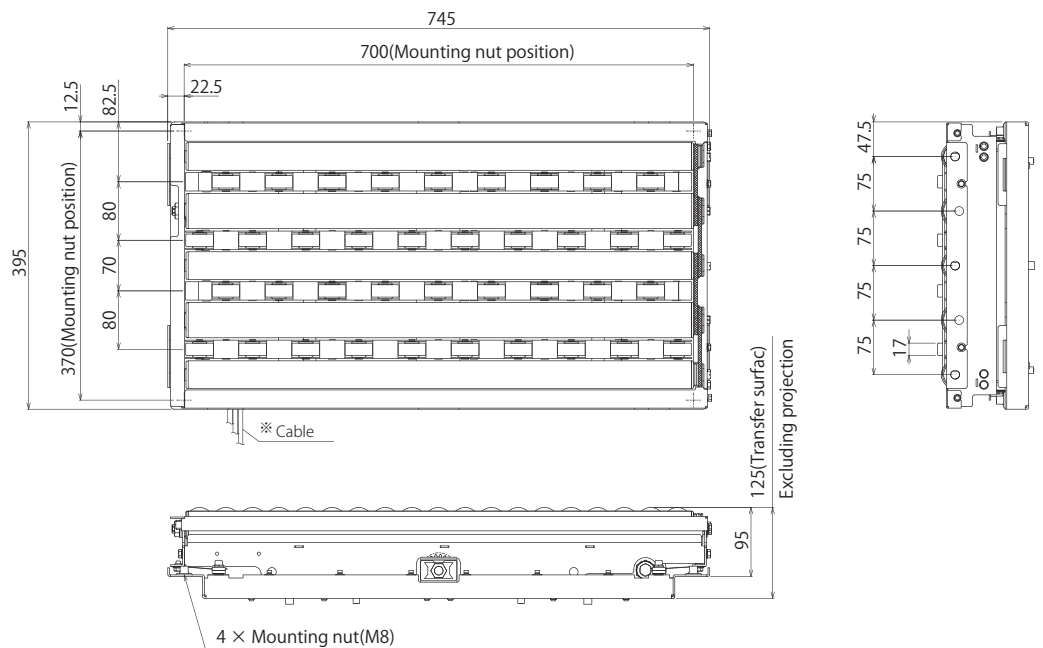

* Guide for cable marginal projecting length (mm)

M1 : Carrier wheel transfer MDR	850
M2 : Roller transfer MDR	1100
M3 : Drive switching MDR	1200

7. Installation/Wiring

Size 7550
L745mm×W495mm

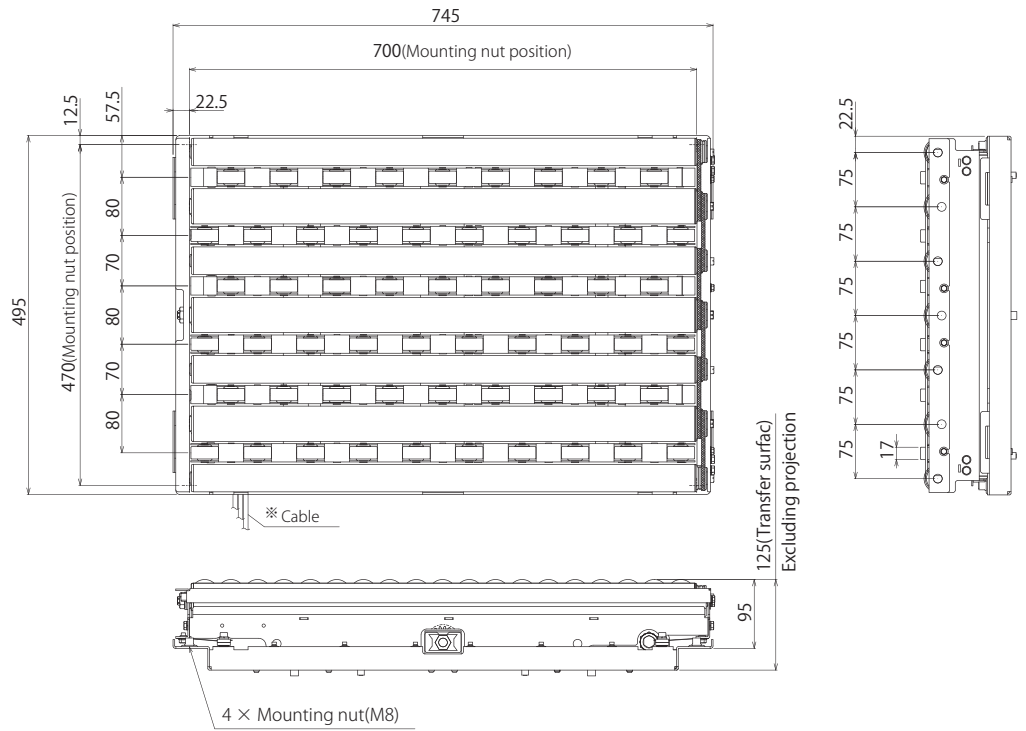

* Guide for cable marginal projecting length (mm)

M1 : Carrier wheel transfer MDR	850
M2 : Roller transfer MDR	1000
M3 : Drive switching MDR	1200

Size 7560
L745mm×W595mm

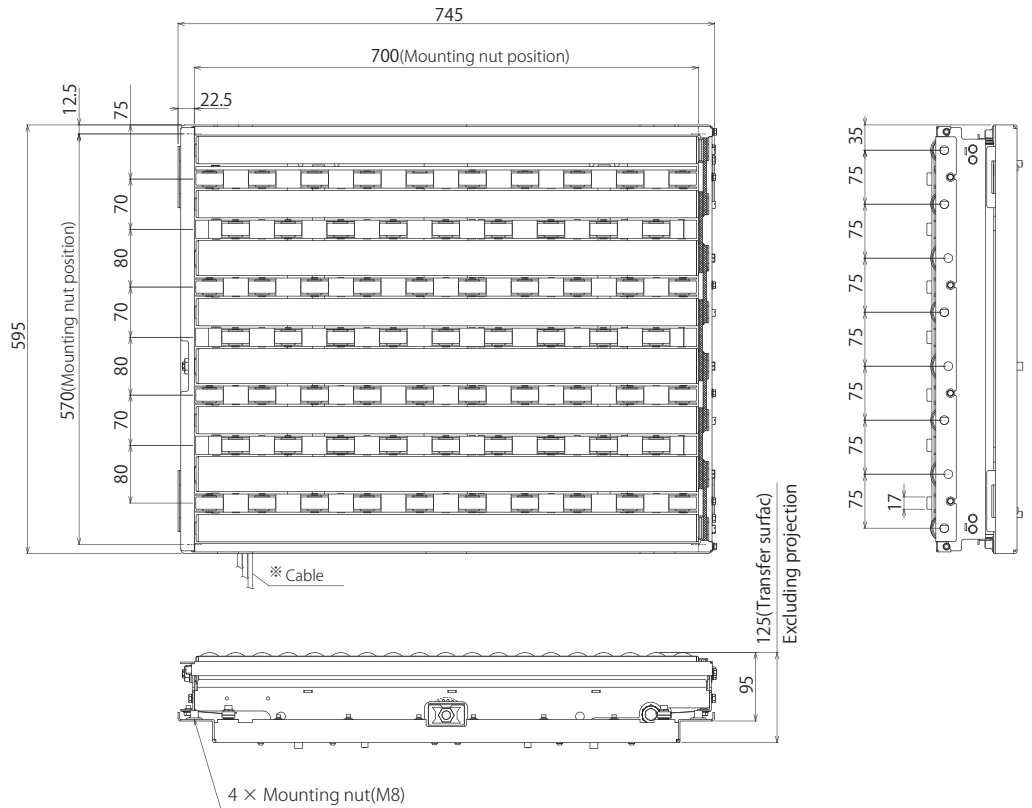

* Guide for cable marginal projecting length (mm)

M1 : Carrier wheel transfer MDR	850
M2 : Roller transfer MDR	900
M3 : Drive switching MDR	1200

7. Installation/Wiring

Size 9040
L895mm×W395mm

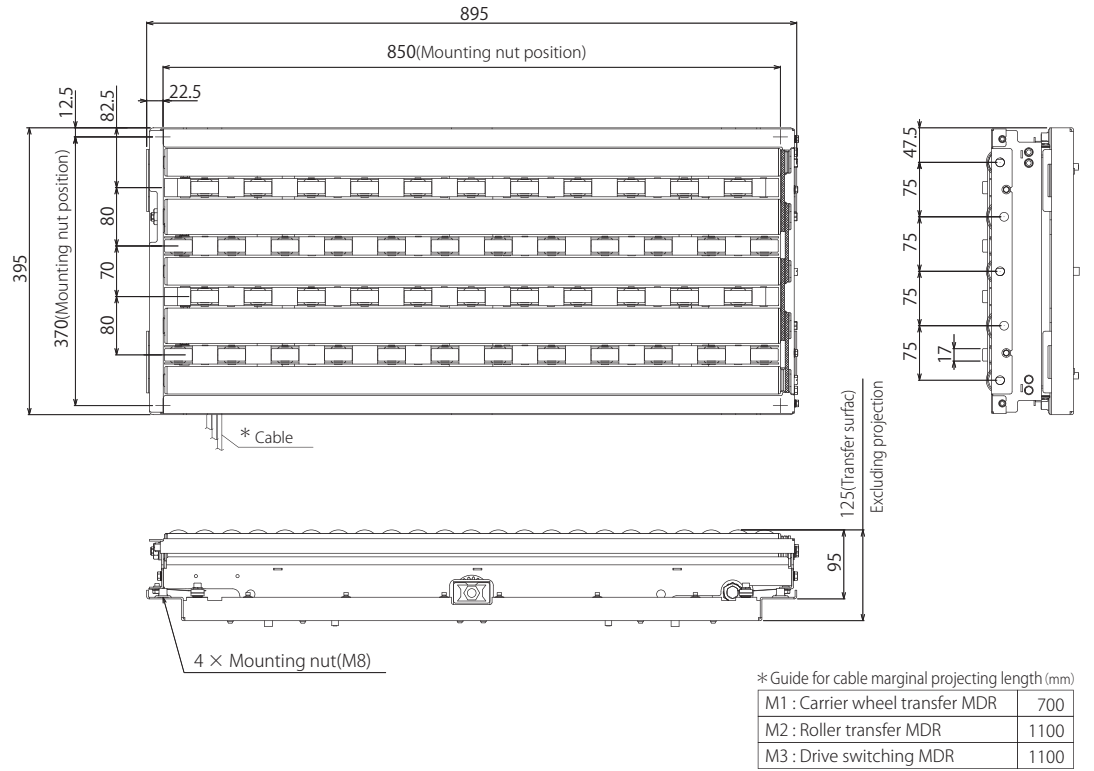

Size 9050
L895mm×W495mm

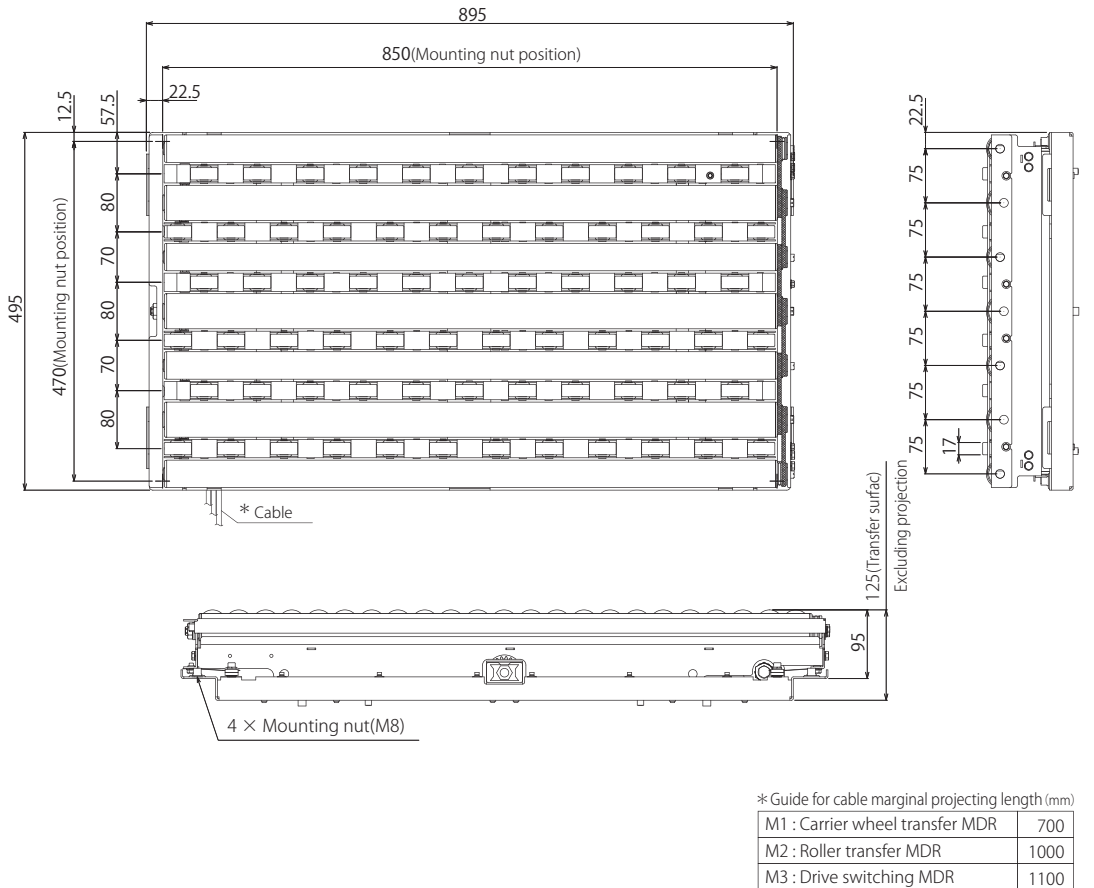

7. Installation/Wiring

Mounting preparation for driver cards

Hole processing on frames and control panel

- Perform mounting processing on the frames and control panel by reference to the mounting holes for driver cards.
 - For cable opening and projection from the F-RAT main unit, refer to Mounting preparation for the F-RAT main unit (P.25).

! Mount driver cards on a flat surface where heat can be released easily.
! Prevent chips generated during processing from entering driver cards.

IB-E04F-FT

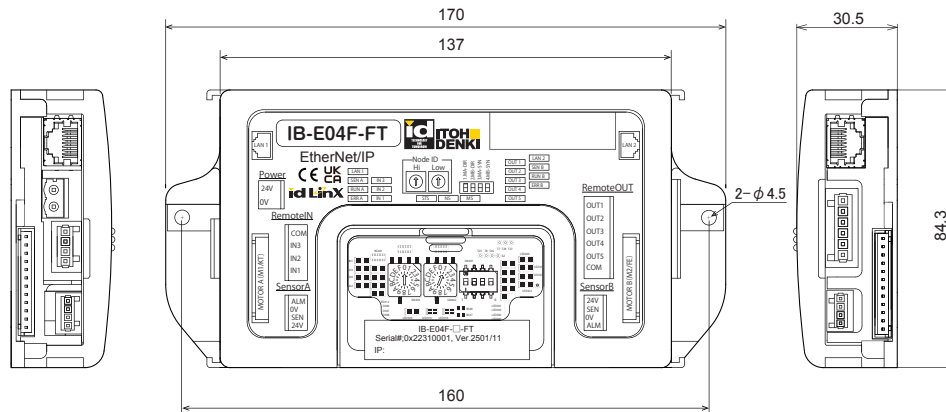

HBM-201

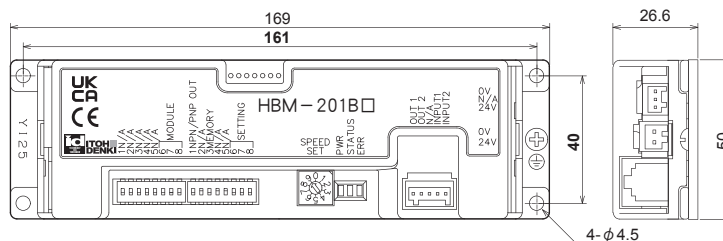

Preparation of MDR extension cables

If the mounting location of the F-RAT main unit is far from that of driver cards, prepare the MDR extension cables separately.

- 12P extension cable : F-RAT [M1 / M2] — IB-E04F-FT [MA] . . . ACE-CBM-G○○○○
- 10P extension cable : F-RAT [M3] — HBM-201 ACE-CBM-A○○○○

! Use extension cables of 1200 mm or less.
! Do not extend cables by connecting multiple extension cables.

Mounting preparation for sensors

Determine the mounting location for zone sensors, and area sensors for loading and discharging, and prepare for them to be mounted.

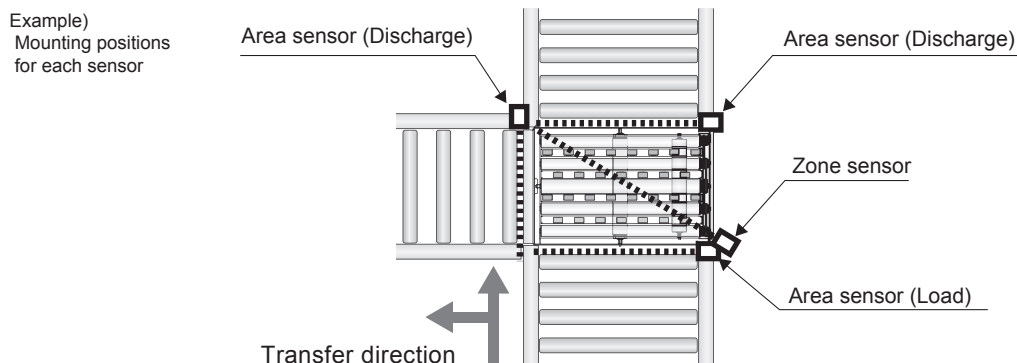

Safety precautions

Advance preparation

Product check

Structures

Installation/Wiring

IB-E04F-FT settings

Control/Operation

Maintenance/Inspection

Troubleshooting

Appendix

7. Installation/Wiring

7-2. Installation

Installing the F-RAT main unit

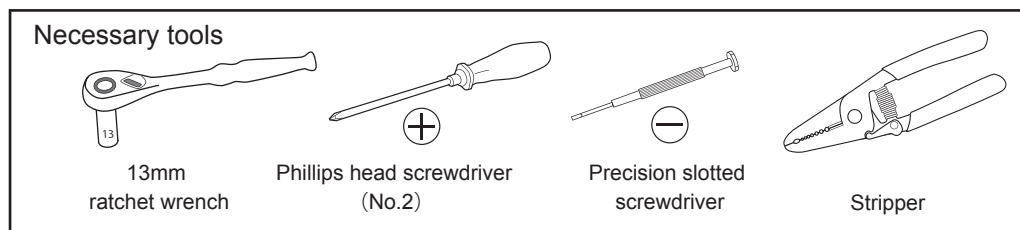

Installing the F-RAT main unit

1 Carry this product to the installing location.

! When lifting, hold the bottom of this product. Do not hold the moving parts, such as rollers, belt transfer parts, or lifting sections.

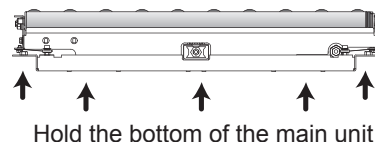

2 Check the installing direction for the loading/discharging sides.

! Check the direction of V-ribbed pulley.

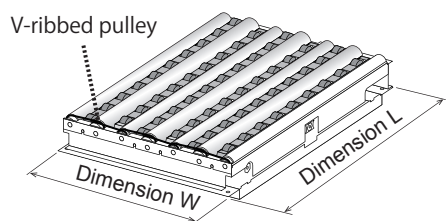

3 Use the included bolts to secure the unit on stands or stays with the mounting nuts for the F-RAT main unit.

!

- When installing, be careful not to get fingers caught.
- Install this product in places with a mounting surface tilt (inclination) of 0.5% or less.
- Install in locations where the weight of this product and trays can be sufficiently supported. (For the main unit weight, refer to P.72)
- The vibration level in the installation environment for this product should be 0.5 G or less.
- Secure the working space for maintenance around this product.
- Observe safety regulations required for installation locations or equipment in use.
- **Recommended tightening torque: 12 to 15 N·m**

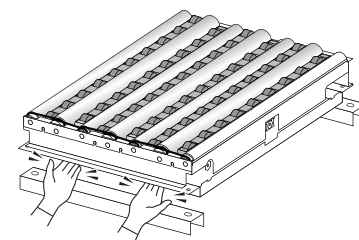

Mounting example using stays

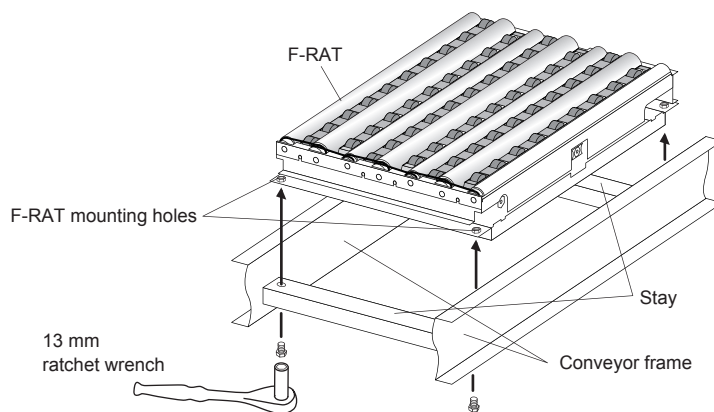

4 Adjust the conveyor frame legs on which the F-RAT main unit has been mounted, and align levels of the F-RAT main unit and the adjacent conveyor.

Safety precautions

Advance preparation

Product check

Structures

Installation/Wiring

IB-E04F-FT settings

Control/Operation

Maintenance/Inspection

Troubleshooting

Appendix

7. Installation/Wiring

About stays (option)

Dedicated stay (optional) is prepared for F-RAT installation.



- If users do not use the stays, be sure to use the mounting holes on the F-RAT main unit to secure the F-RAT. In addition, comply with the mounting dimensions for stays, as well as mount them by taking into consideration the weight of this product and trays.

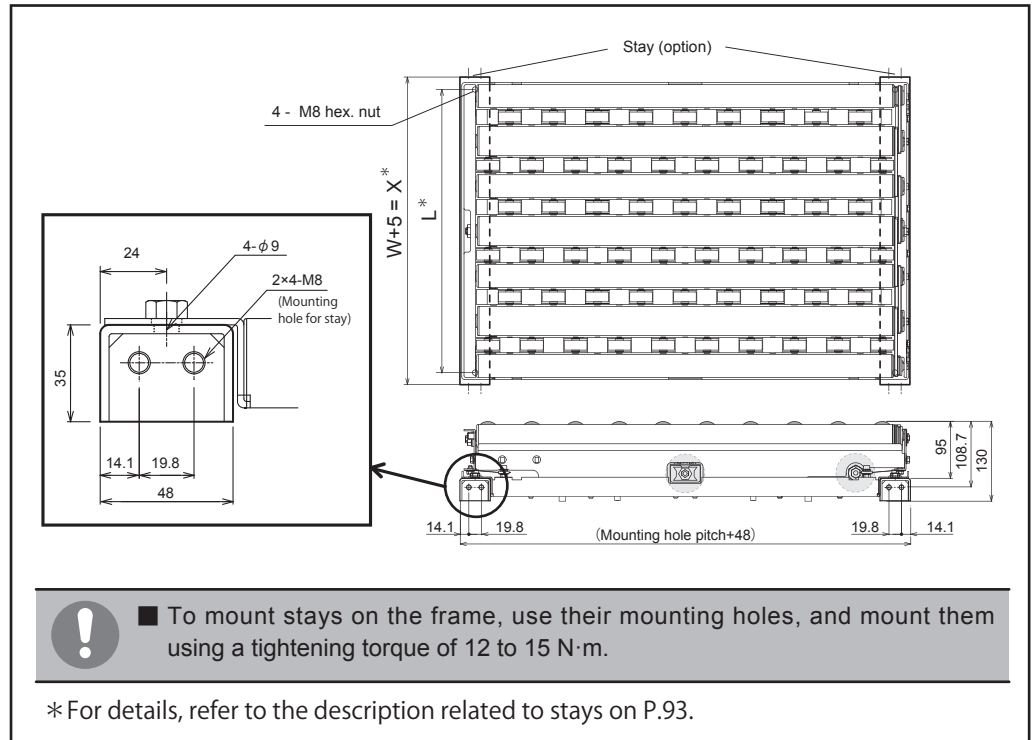

7. Installation/Wiring

Mounting driver cards

Mounting driver cards

Use the included screws and nuts to mount driver cards on the conveyor frames or control panel.



Recommended tightening torque

- IB-E04F-FT : 0.74N·m
- HBM-201 : 1.0N·m

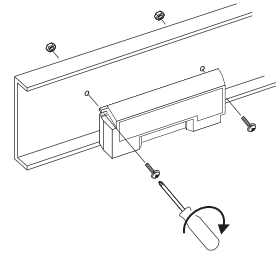

Mounting sensors, control devices, and power supply units

Mounting sensors, control devices, and power supply units

Mount customer-prepared zone sensor and area sensor for loading and discharging, as well as power supply units, and PLCs.

7-3.

Wiring

Connection between the F-RAT main unit and driver cards

Connection between the F-RAT main unit and driver cards

- Refer to the labels for cables coming from the F-RAT main unit, and securely connect the MDR connectors and driver cards.
- When using extension cables, securely connect them to the MDR connectors, as well as to the driver card connectors.

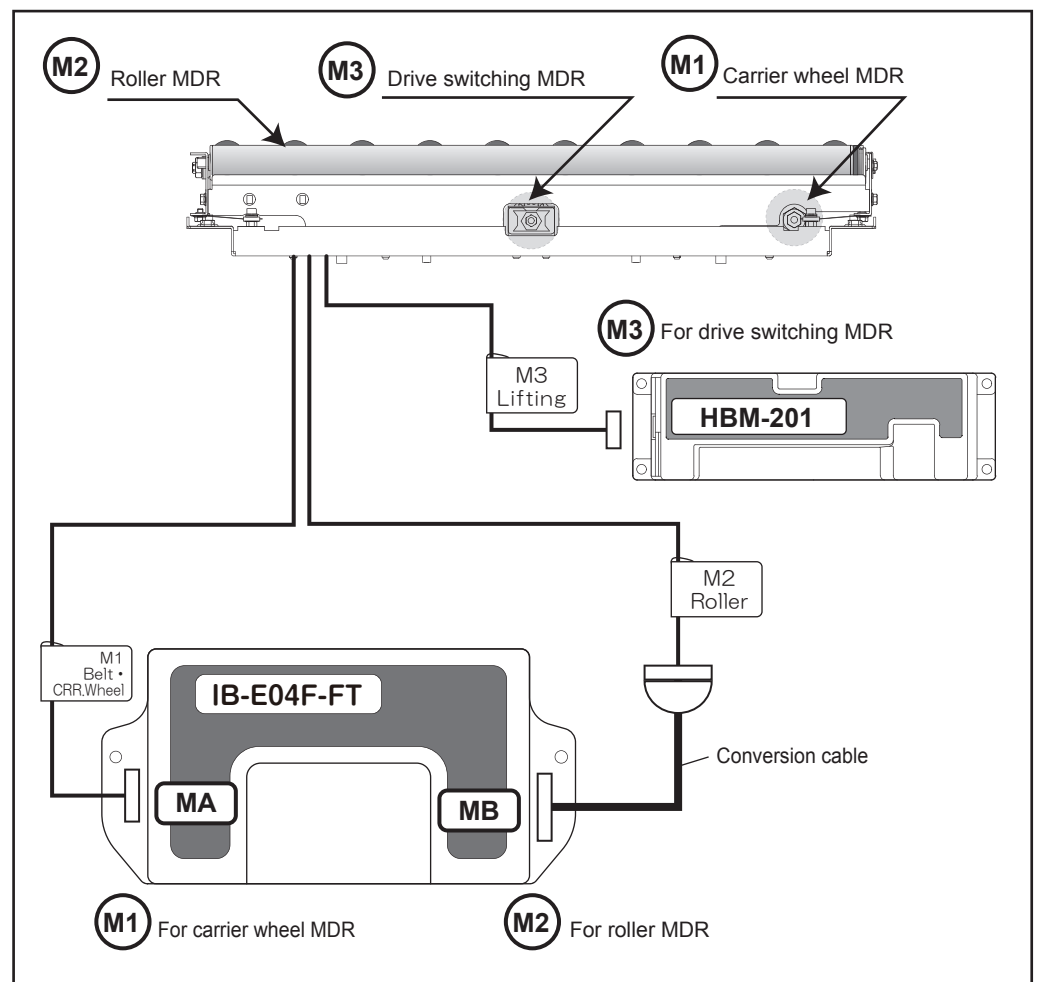

7. Installation/Wiring

Wiring example (image)

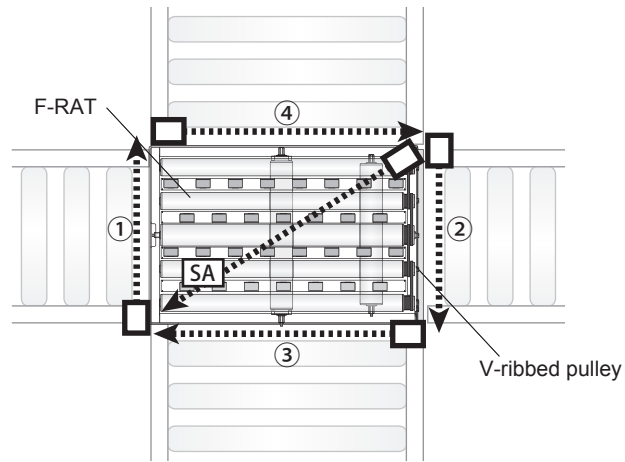

- SA** : F-RAT zone sensor
- ① : Area sensor (on the opposite side of V-ribbed pulley)
- ② : Area sensor (on the side of V-ribbed pulley)
- ③ : Area sensor (on the left side when viewing V-ribbed pulley from the front)
- ④ : Area sensor (on the right side when viewing V-ribbed pulley from the front)

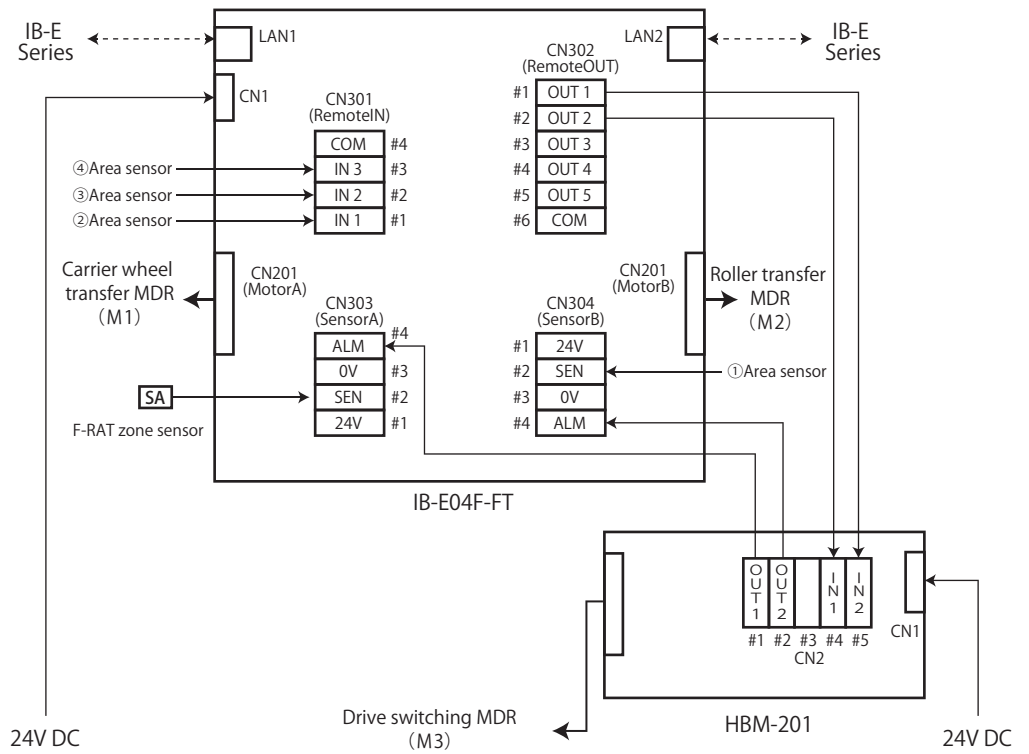

7. Installation/Wiring

{IB-E04F-FT}

IB-E04F-FT wiring

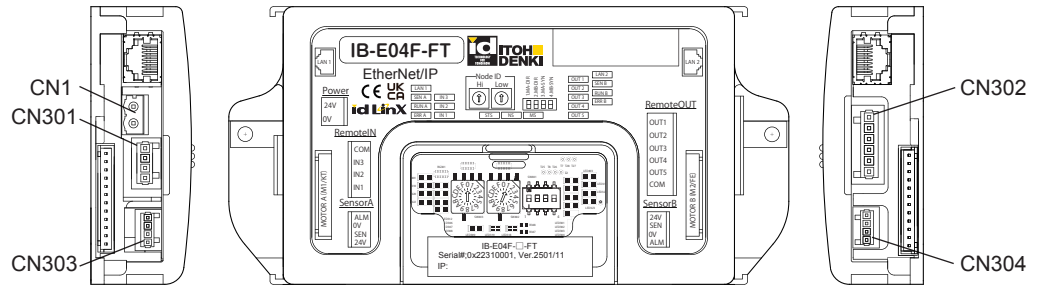

CN1 : Power connector



- #2 24V DC
- #1 0V

CN303/CN304 : Sensor connector

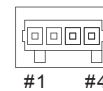

- #1 24V
- #2 Sensor input
- #3 0V
- #4 Alarm input

CN301 : Remote input connector

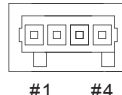

- #1 RemoteIN1
- #2 RemoteIN2
- #3 RemoteIN3
- #4 COMMON

CN302 : Remote output connector

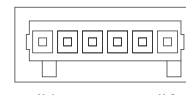

- #1 RemoteOUT1
- #2 RemoteOUT2
- #3 RemoteOUT3
- #4 RemoteOUT4
- #5 RemoteOUT5
- #6 COMMON

CN1 : Power connector

1 Connect the 24V DC and 0V cables to CN1 (2 pin).



- Do not connect multiple power cables to one pole. Failure to follow this could result in electric shock, short circuit, and/or damage due to the capacity of connectors being exceeded. (Connector capacity: 16A)
- Do not connect the 24V DC and 0V cables incorrectly.
- Do not connect cables when connectors are plugged in.

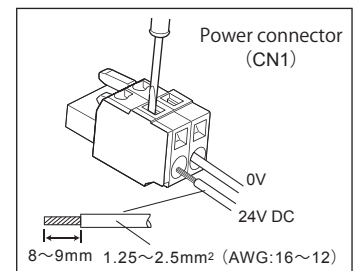

CN301 ~ CN304 : Remote input/ Remote output/ Sensor connector

2 Connect customer-prepared sensor input/output cables to each connector.

※Refer to the wiring example image (P.38), and perform wiring according to operation.

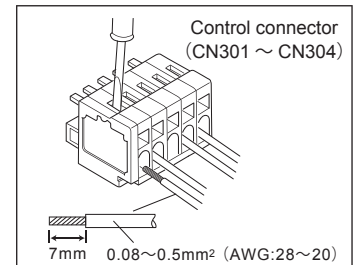

Connecting to driver cards

3 Connect the power connector (CN1) and control connector (CN301 - CN304) to driver cards.

7. Installation/Wiring

Input/output circuit

! Connect the COMMON terminal for remote input and remote output separately.

CN301 [Remote input (CN301)] 734-264 (WAGO) Maximum allowable current: 10A

- Set the NPN/PNP signal switching for remote input using COMMON.
- Note that COMMON is common among RemoteIN1 to 3.

Remote input interface circuit diagram

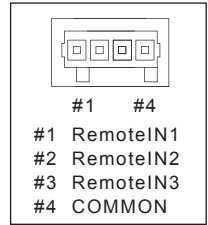
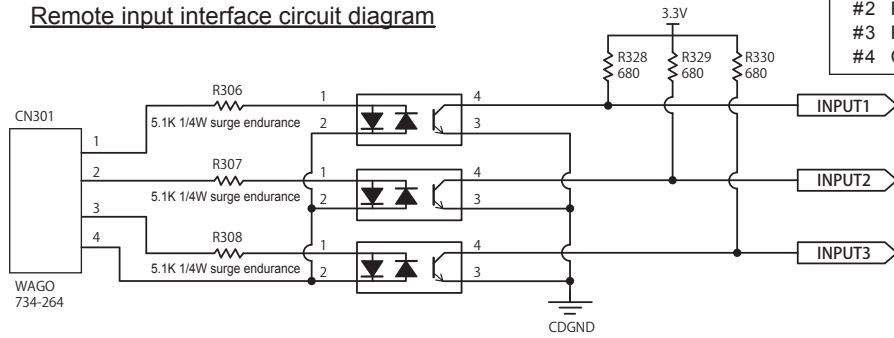

! Set the voltage used for remote input within the range of 18V DC to 30V DC.

CN302 [Remote output (CN302)] 734-266 (WAGO)

- Set the NPN/PNP signal switching for remote input using COMMON.
- Note that COMMON is common among RemoteOUT1 to 5.

Remote output interface circuit diagram

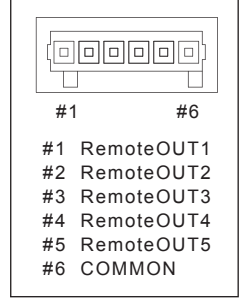
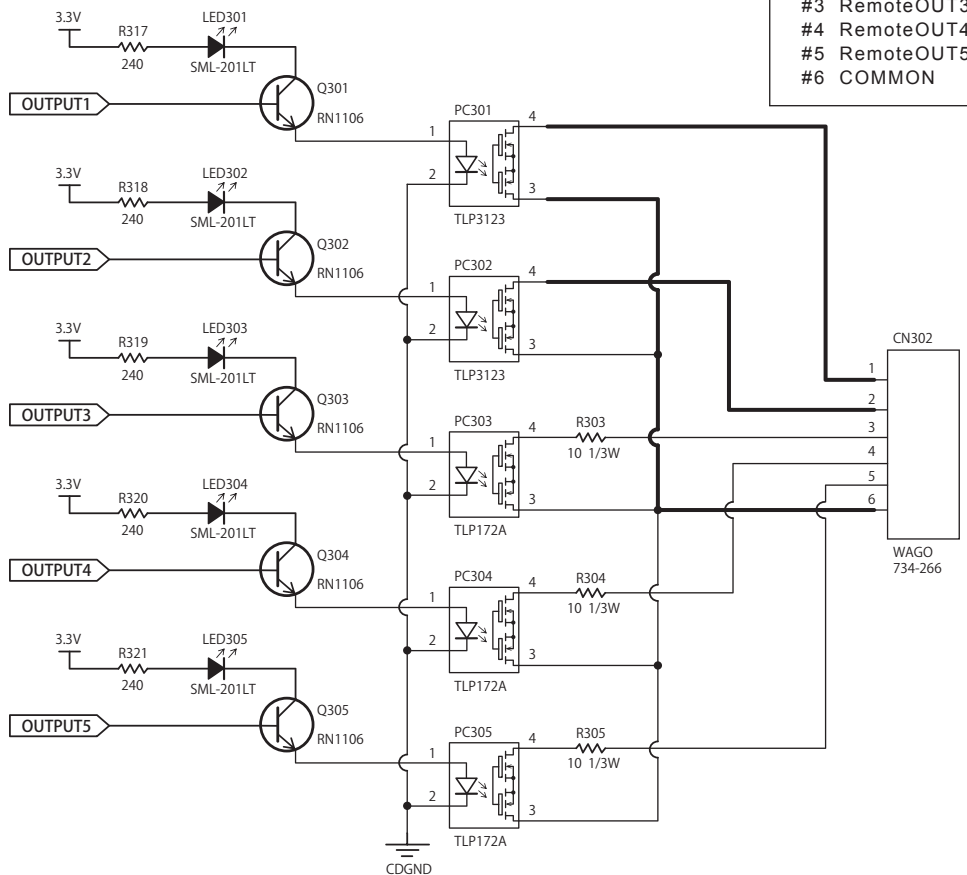

! Set the voltage used for remote output within the range of 18V DC to 30V DC.

! The maximum output current value for remote output is 1A on #1 and #2, and 200mA on #3 to #5.

Safety precautions
Advance preparation
Product check
Structures
Installation/Wiring
IB-E04F-FT settings
Control/Operation
Maintenance/Inspection
Troubleshooting
Appendix

7. Installation/Wiring

{HBM-201}

M3 : Drive switching

Wiring for HBM-201

HBM-201

■ Connector descriptions

CN1 (Power)	#2	0V
	#1	24V DC

#2	0V
	#1

		Functions		Detailed descriptions	
CN2 (Control)	#5	Input	Carrier wheel surface switch input	• Carrier wheel and roller transfer surface are switched by inputting signal • Teaching* settings can be performed when both #4 and #5 are ON	
	#4	Input	Roller surface switch input		
	#3	—	Unused		
	#2	Output	Carrier wheel surface standby output	• Teaching* has not completed when both #1 and #2 are ON (when the power is turned on) • Transfer surfaces are being switched, and teaching is in operation when both #1 and #2 are OFF • Open collector output (Attach protection resistance so that the output is 25mA or less.)	
	#1	Output	Roller surface standby output		

#1 #2 #3 #4 #5

Power connector (CN1)

1 Connect the 24V DC and 0V cables to CN1 (2 pin).



- Do not connect multiple power cables to one pole. Failure to follow this could result in electric shock, short circuit, and/or damage due to the capacity of connectors being exceeded. (Connector capacity: 10A)
- Do not connect the 24V DC and 0V cables incorrectly.
- Do not connect cables when connectors are plugged in.

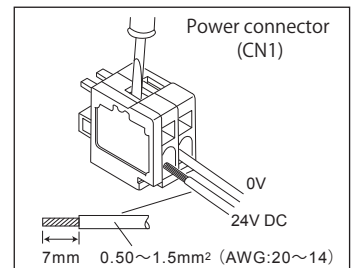

Control connector (CN2)

2 Connect the above four cables.



- Use the same voltage to be input to CN2#1 as the power supply voltage. (Connector capacity: 4A)

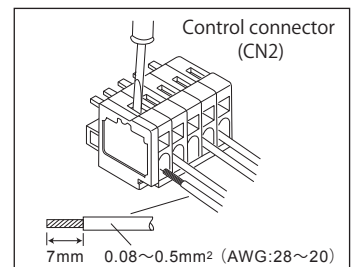

Connecting to driver cards

3 Connect the power connector (CN1), and control connector (CN2) to driver cards.



* Teaching

Operation to perform the initial setting of the transfer surface position. Teaching must be performed after the power is turned on.

Term

7. Installation/Wiring

Switch settings

- Turn the driver card DIP switch and rotary switch to the following (factory setting).

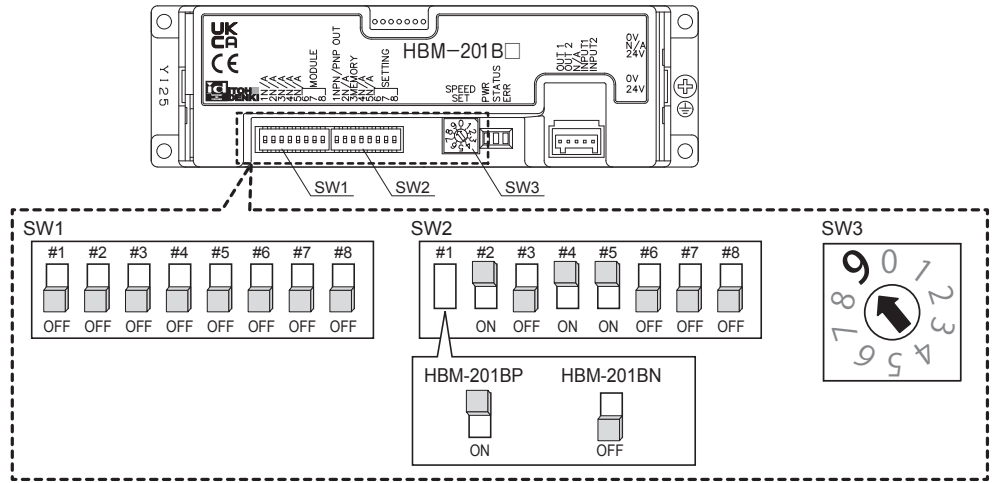

! Do not change the factory settings.

8. IB-E04F-FT settings

8-1. Setting preparation	45
8-2. Property settings	48

8. IB-E04F-FT settings

Flow of settings

IB-E04F-FT controls the F-RAT with the property settings and ladder logic. This section explains the setting preparation and property settings.

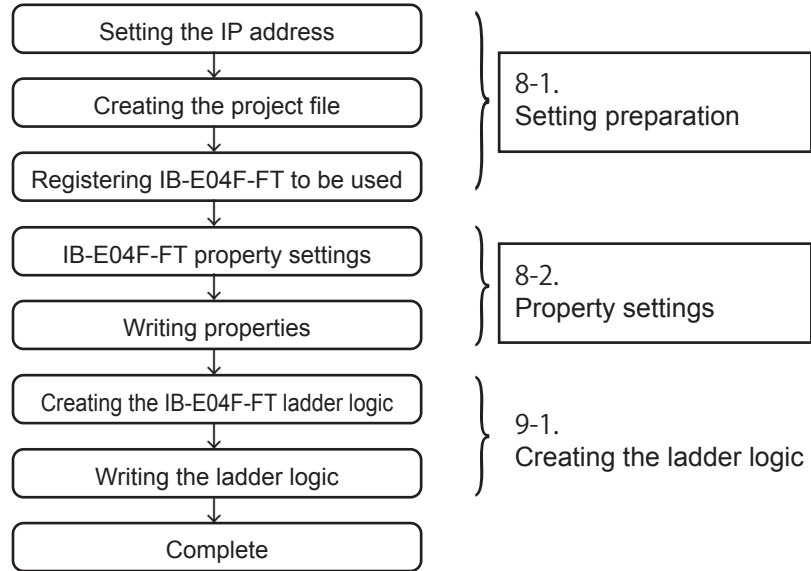

8. IB-E04F-FT settings

8-1. Setting preparation

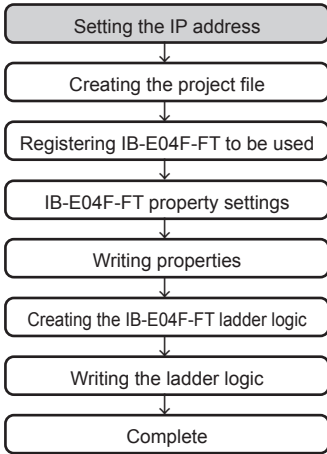

Controller settings

Make sure that all DIP switches on SW401 of IE-B-E04F-FT are turned OFF.

! All switches are OFF under the factory settings. Do not change.

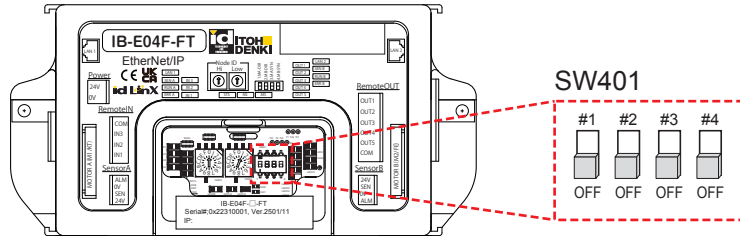

IB-E04F-FT IP address and gateway address settings / connection check

"192.168.1.1 / 255.255.255.0" has been set under the IB-E04F-FT factory settings.

- Change the "xx" part of the IP address "192.168.1.xx" with the IB rotary switches SW402 and SW403.
 - ※For specifications of the rotary switches SW402 and SW403, refer to Chapter 1 "1.3 IB-E03B/E04F switch settings" in the ICE instruction manual separately.

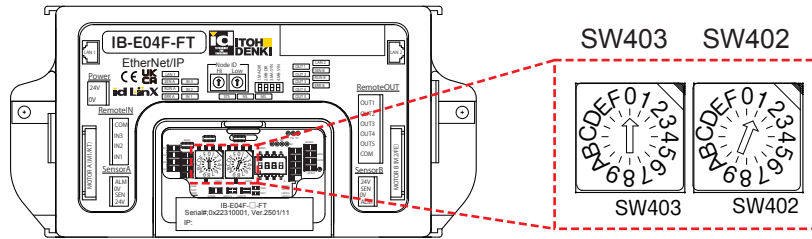

! Avoid overlapping IP address.

- Connect the PC and IB-E04F-FT with the LAN cable, and turn on the power to IB-E04F-FT and HBM-201.
- Set the IP address for the PC to "192.168.1.1 / 255.255.255.0".

- Open "Control Panel" - "Network and Sharing Center", and click "Local Area Connection".



- Open "Properties", and select "Internet Protocol Version4 (TCP/IPv4)". Click "Properties"

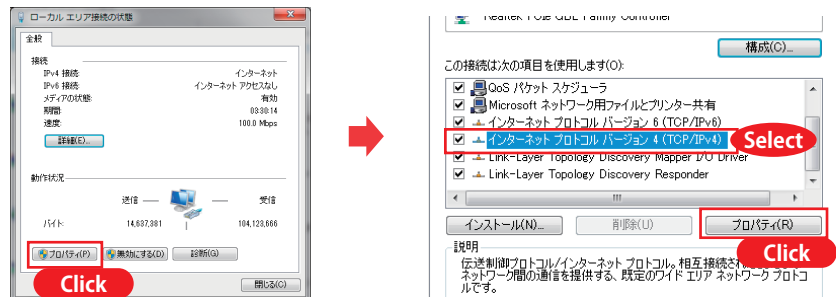

Safety precautions

Advance preparation

Product check

Structures

Installation/Wiring

IB-E04F-FT settings

Control/Operation

Maintenance/Inspection

Troubleshooting

Appendix

8. IB-E04F-FT settings

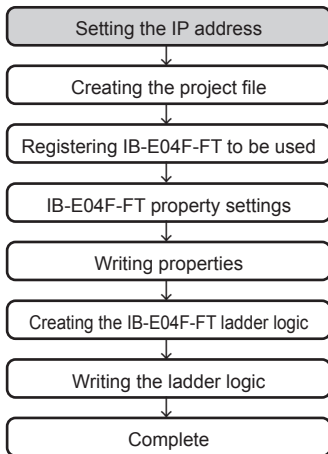

3 Set the IP address to “192.168.1.XXX”, and Subnet mask to “255.255.255.0”. Click “OK”.

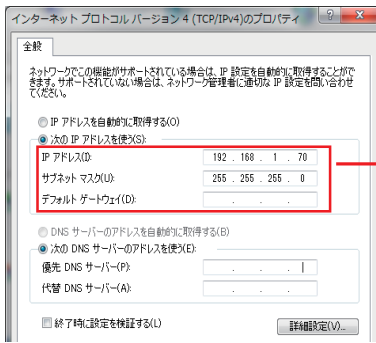

IP address → 192.168.1.XXX
 Subnet mask → 255.255.255.0
 Default gateway → 192.168.1.254

! Do not use the same IP address used for other devices, such as IB-E04F-FT.

4 Check connection between the PC and IB-E04F-FT.

1 Start ICE, and select “Dialog” - “Discovery” from the main menu.

! Use ICE Ver1.1.4.0 or later.
 IB-E04F-FT cannot be used with the version released before ICE Ver 1.1.4.0.

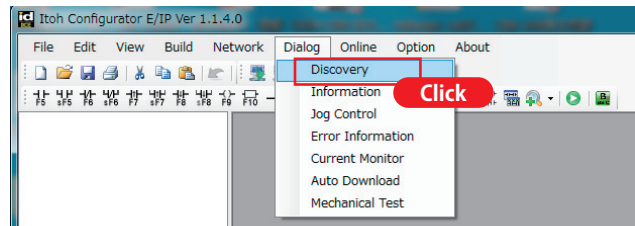
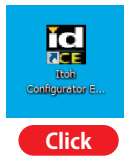

2 Set the IP address for the PC you are using under ‘IP Address’, and click ‘Discovery’.

! If the IP address for the PC you are using is not displayed, the PC has not been connected to IB-E04F-FT.
 Re-check the LAN cable and IP address for the PC.

3 Select the current network (‘192.168.1.xx’) under ‘Select Network’.
 Nodes for which the connection has been confirmed will turn blue under ‘Network Status’.

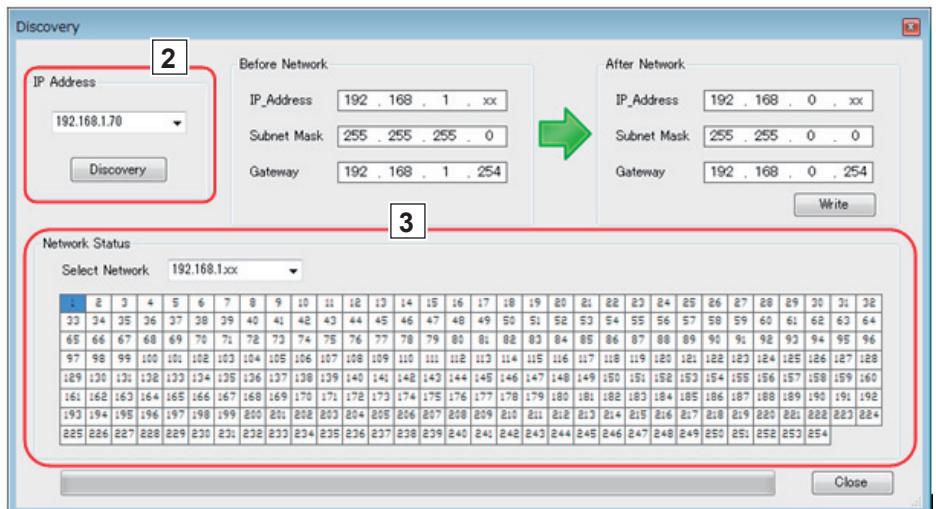

When changing the network address and gateway address, check “2.2 Initial settings (P.2-8)” in the ICE instruction manual separately.

Safety precautions
 Advance preparation
 Product check
 Structures
 Installation/Wiring
 IB-E04F-FT settings
 Control/Operation
 Maintenance/Inspection
 Troubleshooting
 Appendix

8. IB-E04F-FT settings

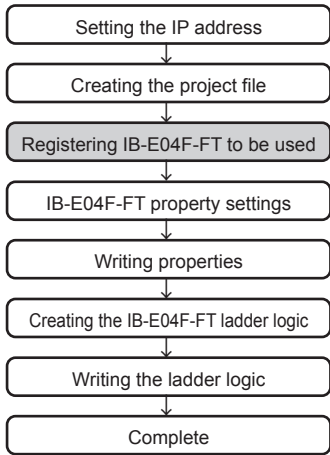
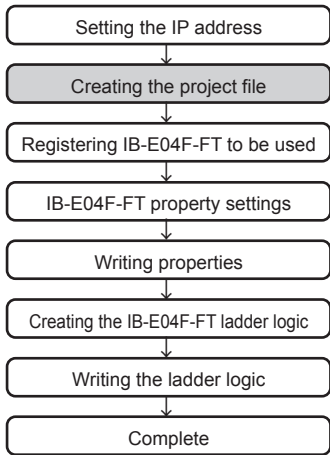

Creating the project file

Before creating the ladder logic and setting properties for the F-RAT, the project file needs to be created by ICE.

- 1 Select 'New Project' from the main menu.

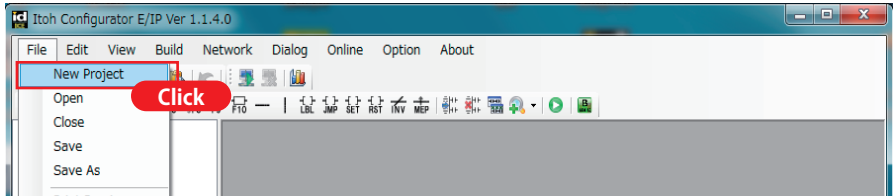

- 2 Set the project name and save location for the project file, and click 'OK'. The default save location is the 'ICE Project' folder directly under the 'Documents' folder.

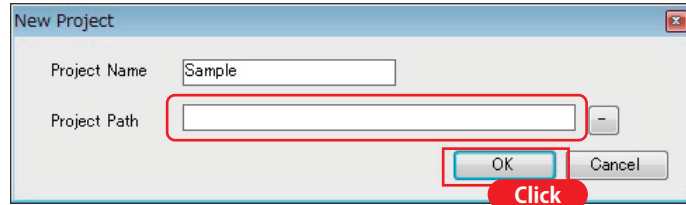

Registering IB-E04F-FT to be used

Before executing operations, such as writing the ladder logic and/or property settings to IB-E04F-FT, IB-E04F-FT to be used needs to be registered.

- 1 Open the project from the project tree window, right-click 'Device', and click 'Add'.

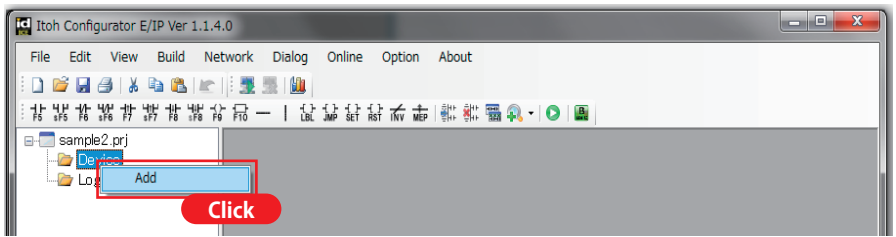

- 2 Enter the network address for IB-E04F-FT.

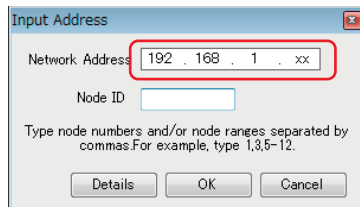

- 3 Set the NodeID (the part 'xx' of Network Address) for IB-E04F-FT.
 ※The NodeID is the value specified by SW402 and SW403 on IB-E04F-F.

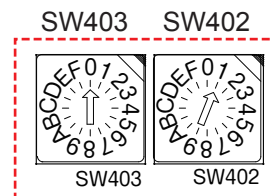
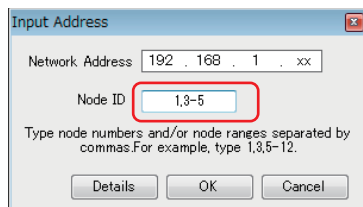

This completes the setting preparation.

8. IB-E04F-FT settings

8-2.

Property setting

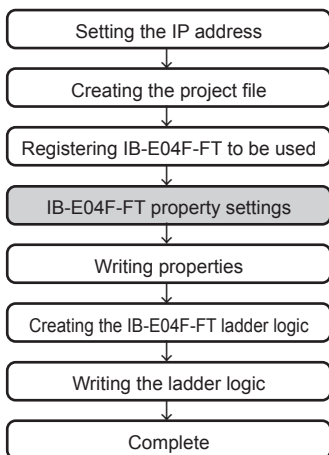

Property setting

In the property settings, set the F-RAT ladder logic selection and transfer speed to be written to IB-E04F-FT.

- 1 Click 'Device' on the project tree window, and display the IP address for the corresponding IB-E04F-FT.
- 2 Double-click 'Property' to open the property setting window.

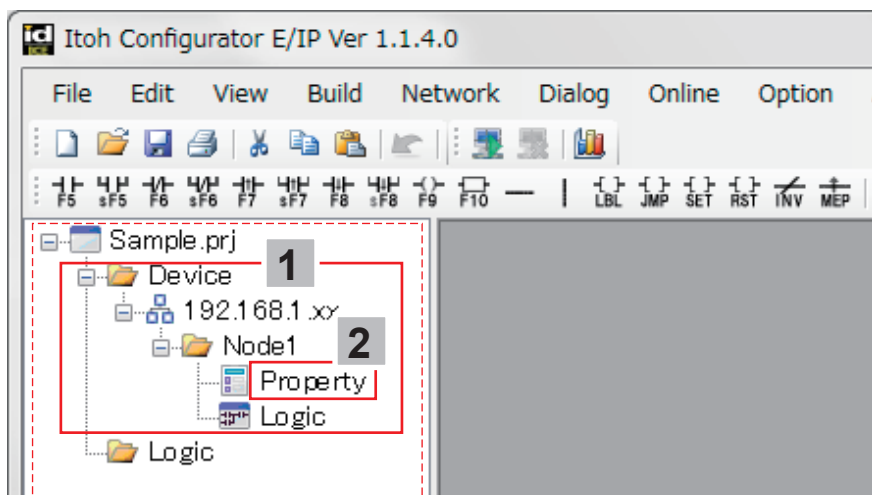

Project tree window

8. IB-E04F-FT settings

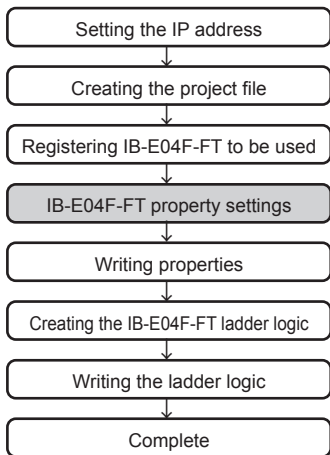

Property setting window

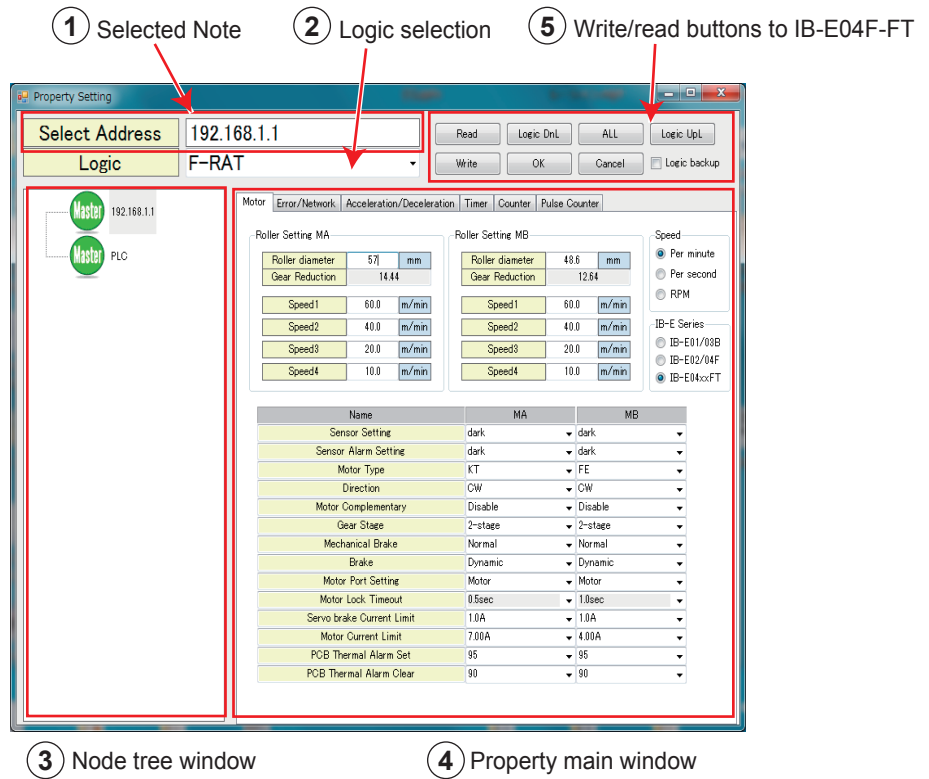

- ① Selected Note
The IP address for the IB of for which the properties are being specified is displayed. Double-click Node on the '(3) Node tree window' to switch the selected Node.
- ② Logic selection
Select the ladder logic to be written to IB-E04F-FT.
- ③ Node tree window
Set the master or slave for IB-E04F-FT registered in the project.
- ④ Property main window

Motor	Settings related to motor control
Error/Network	How to release error and driver cards communications settings
Acceleration/Deceleration	Settings for motor's acceleration / deceleration
Timer	Ladder logic timer value settings
Counter	Ladder logic count value settings
Pulse Counter	Ladder logic count value settings

- ⑤ Write/read buttons to IB-E04F-FT

Read	Reads the property settings from IB-E04F-FT.
Write	Writes the property settings.
Logic DnL	Writes the ladder logic.
OK	Maintains the changed property settings, and closes the property setting window.
ALL	Writes the ladder logic and property settings to multiple controllers.
Cancel	Without maintaining the changed property settings, closes the property setting window.
Logic UpL	Reads the ladder logic from IB-E04F-FT.
Logic backup	Writes the ladder logic for reading together when executing 'LogicDL' with its checkbox selected.

8. IB-E04F-FT settings

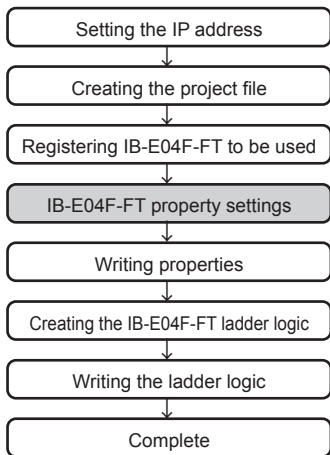

3 Enter the F-RAT settings as described below.

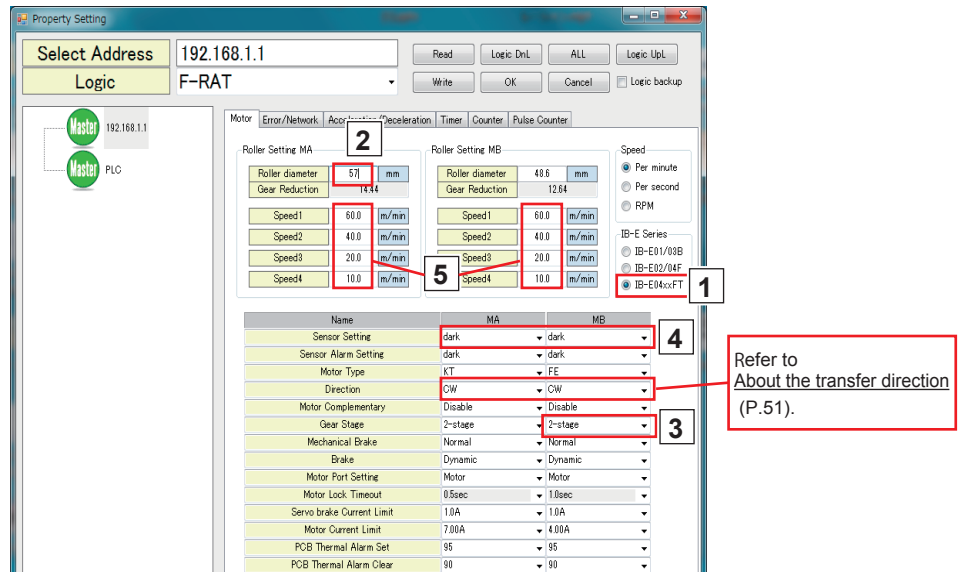

- 1 Select "IB-E04xxFT". ("MA" for Motor Type will turn to "KT")
- 2 Change "Roller diameter" of "Roller Setting MA" to "57".
- 3 Change "MB" of "Gear Stage" according to the F-RAT nominal speed.

Nominal speed	MB Gear Stage
17m/min	3-stage
60m/min	2-stage

 - Fix "MA" to "2-stage".
- 4 Fit "Sensor Setting" to your sensor setting.
- 5 Register the speed. (Can be selected up to the fourth speed)
Set the registered speed with the ladder logic command.
For details, refer to "2.4 Ladder logic" (P.2-33) in the ICE instruction manual separately.

Roller Setting	Category	F-RAT nominal speed	Speed range	Setting STEP
MA	Carrier wheel speed	—	7.7~66.7m/min	Every 1.28m/min
MB	Roller speed	17m/min	2.1~18.3m/min	Every 0.35m/min
		60m/min	7.5~65.0m/min	Every 1.25m/min



- Values out of the speed range cannot be set.
- The speed can be changed for each setting STEP.
- If a speed that does not conform to the setting STEP has been registered, the approximate speed value that conforms to the setting STEP will be adapted. The registered speed (value on the screen) will not be changed.
- "Speed" indicates the value when trays are not placed on carrier wheels and rollers.
- During operation, the rising time to the setting speed may vary depending on ambient temperature. Perform running operation thoroughly.
- Values described above may differ from the actual transfer speed depending on the weight, material, bottom surface, and/or shape of trays, as well as ambient temperature.

Safety precautions
Advance preparation
Product check
Structures
Installation/Wiring
IB-E04F-FT settings
Control/Operation
Maintenance/Inspection
Troubleshooting
Appendix

8. IB-E04F-FT settings

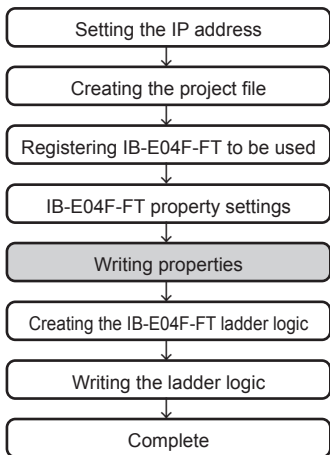

About the transfer direction

Set the transfer direction with the ladder logic command and 'Direction' under properties. For details on the ladder logic, refer to "2.4 Ladder logic" (P.2-33) in the ICE instruction manual separately.

! When switching the rotation direction during transfer (during MDR rotation), the F-RAT will stop for 0.5 seconds, and then the transfer direction will be switched.

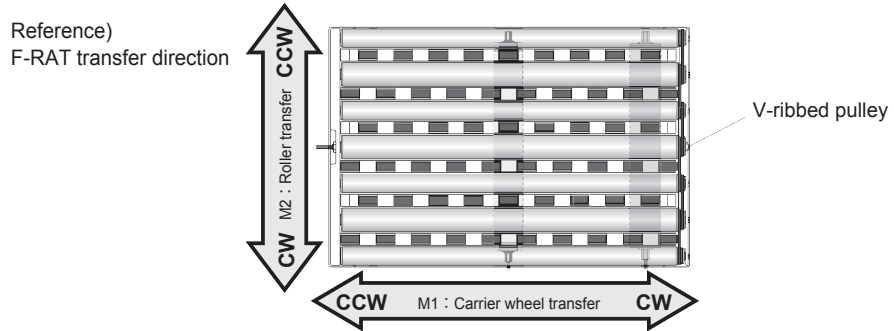

For details and other settings, refer to the ICE instruction manual separately.

4 Write the property settings to IB-E04F-FT. Specified properties cannot be applied until they have been written.

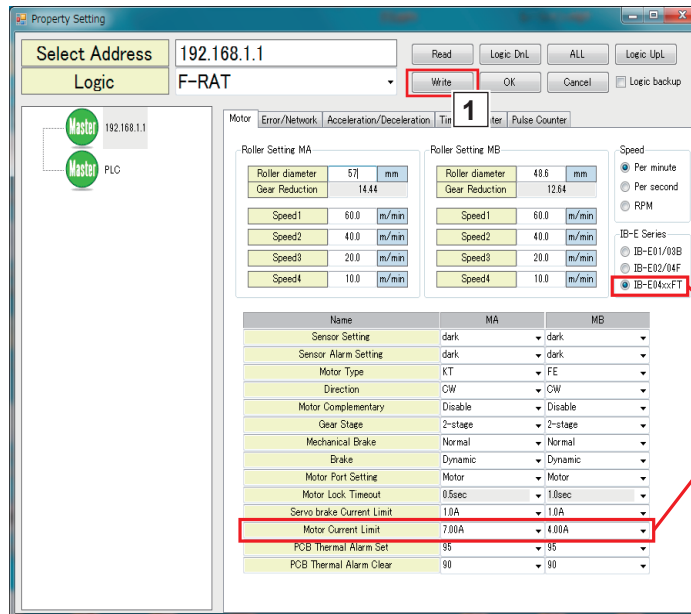

1 Press "Write". When writing is successful, the "Write Completed Successfully" message is displayed.

! Before writing, make sure that IB-E Series is set to IB-E04xxFT, and Motor Current Limit is set to MA:7.0A / MB:4.0A.

This completes the property settings.

Safety precautions
Advance preparation
Product check
Structures
Installation/Wiring
IB-E04F-FT settings
Control/Operation
Maintenance/Inspection
Troubleshooting
Appendix

9. Control/Operation

9-1. Creating the ladder logic	54
9-1-1. Switching the transfer direction	58
9-1-2. Changing the speed	58
9-2. Basic operation	59
9-2-1. Switching the transfer surface	64
9-2-2. About the initial position setting (teaching) of the transfer surface	65
9-3. Program example	66
9-4. What to do before operation	67

9. Control/Operation

Flow of settings

IB-E04F-FT operates the F-RAT with the property settings and ladder logic
This section explains the ladder logic creation and writing.

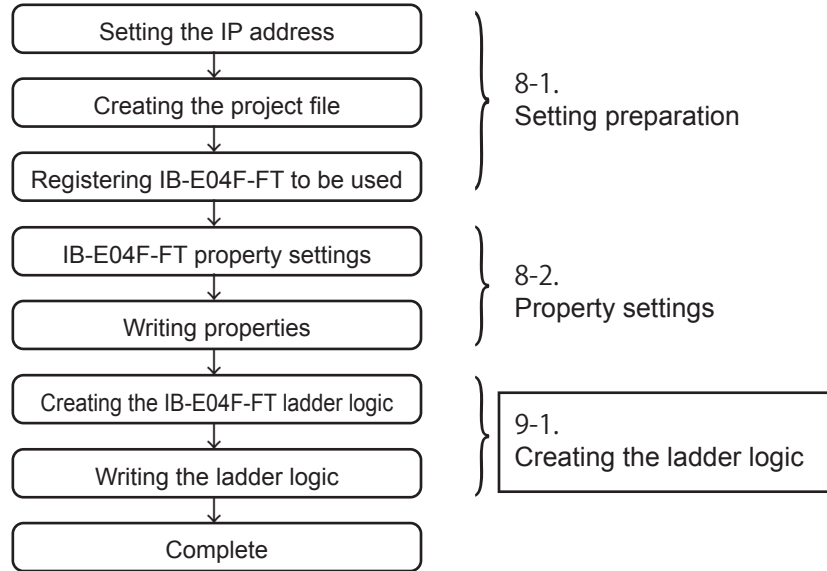

9. Control/Operation

9-1.

Creating the ladder logic

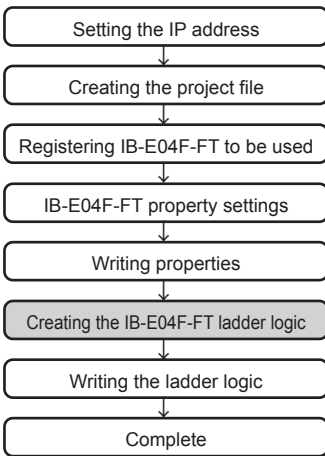

Creating the IB-E04F-FT ladder logic

Create the F-RAT ladder logic to be written to IB-E04F-FT.

- 1 Start ICE, and select “File” - “Open” from the main menu. Then, open the project file that has been created in 8.1 Setting preparation. (For details on creation of the project file, refer to 8.1 IB-E04F-FT settings (P.47), and the ICE instruction manual separately.)

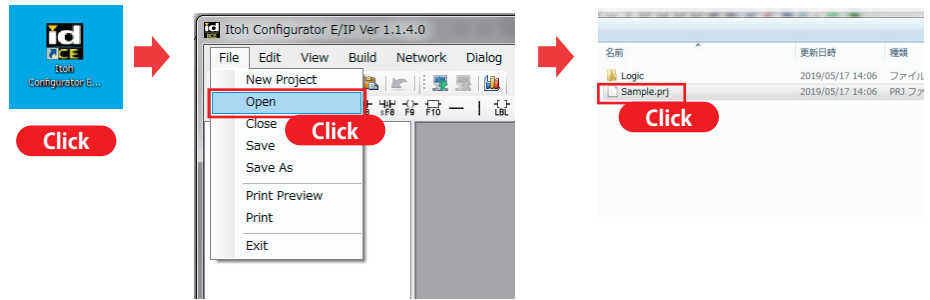

Ladder logic window

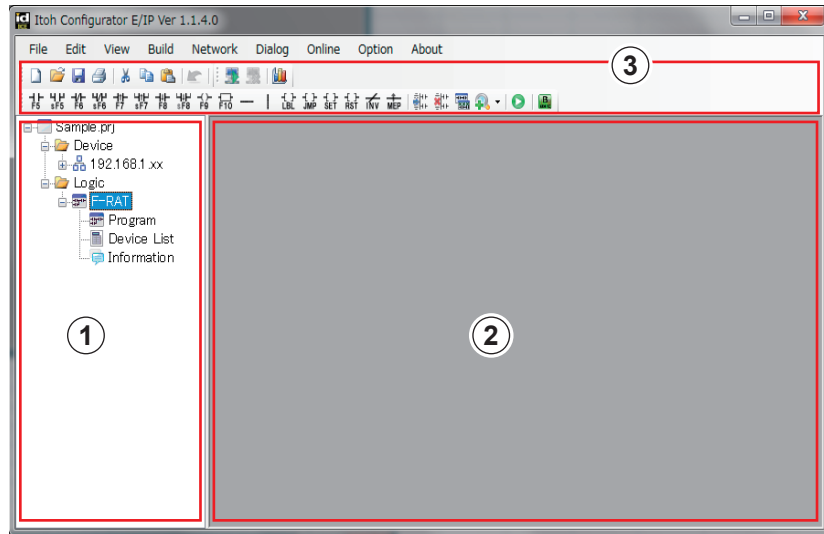

- 1 Project tree window
 Select 'Program' to display the ladder logic on the program window.
 Select 'Device List' to display the contact and relay lists on the program window. Comments can be added to contacts and relays from the lists. Also, the contact and relay status will be displayed during monitoring.
 Select 'Information' to display the logic name, ladder logic's writer name, ladder creation date and time, ladder build date and time, and ladder logic size.
- 2 Program window
 A window for creating the ladder logic, etc.
- 3 Various icons
 Use various icons to describe the ladder logic. For details, refer to “2.1.1 (4) Various icons” in the ICE instruction manual separately.



Ladder logic

A program (ladder logic) to define each motor operation for the IB. The program can be created with the PC application ICE by Itoh (Itoh Configurator E/IP).

9. Control/Operation

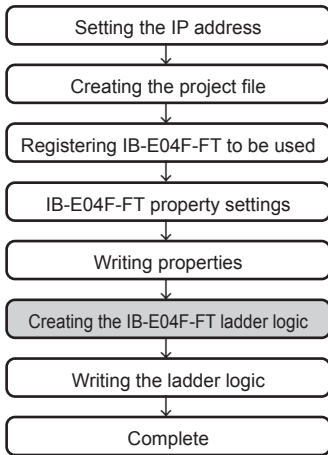

2 Select 'Logic' on the project tree window, and right-click "add" to select. Enter the logic name and creator's name in Logic Information.

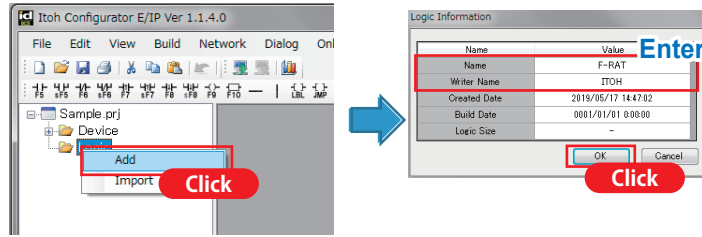

! Only alphanumeric characters can be used.
 Spaces (blank) cannot be used.

3 The name of the logic information is displayed under "Logic" on the project tree window, and "Program", "Device List", and "Information" are likewise displayed.

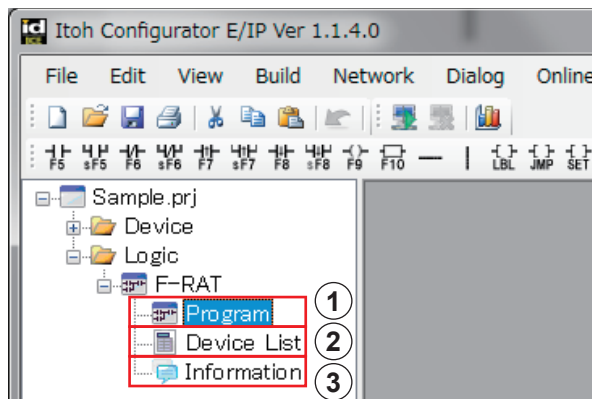

Description of each window

1 Program window

Double-click 'Program' to display the program window as below. Contacts will be entered at the cursor position. The ladder logic name is displayed at the lower left of the window, and the ladder logic size is displayed at the lower right of the window. The ladder logic size will be updated per build.

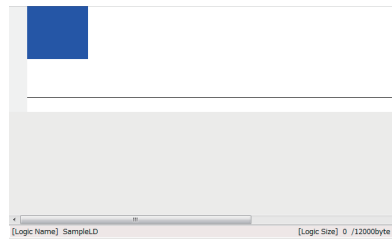

2 Device List window

Double-click 'Device List' to display the program window as below. Select X, Y, M, D, T, C, PC, S, or SD for 'Device Type' to display the list of selected contacts. Comments can be entered in the Comment field. The current value will be displayed in the Value field during ladder monitoring.

Address	Device Type	Value	- -	-(-)
0	Y	-	*	
1	M	-	*	
2	D	-		
3	T	-		
4	PC	-		
5	S	-		
6	SD	-		
7	Sensor Alarm A	-		
8	Sensor Alarm B	-		
9	Reserved	-		
10	Reserved	-		
11	Reserved	-		
12	Reserved	-		
13	Reserved	-		
14	Reserved	-		
15	Reserved	-		

Comment field Value field

Contact usage status ("*" will be displayed when used)

Output usage status ("*" will be displayed when used)

9. Control/Operation

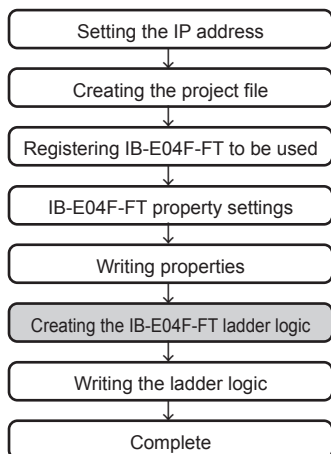

3 Information window

Double-click 'Information' to open the Logic Information window.

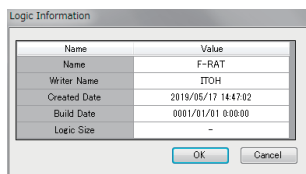

4 Create the ladder logic on the program window.

- F-RAT operation → Refer to 9-2. Basic operation
- Creating the ladder logic → Refer to the ICE instruction manual separately

9. Control/Operation

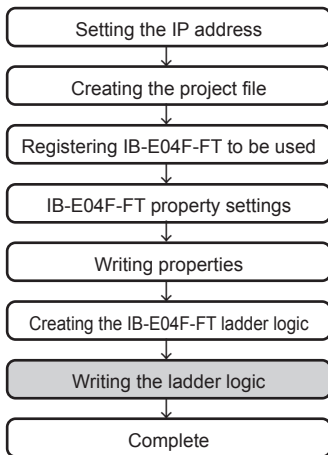

Writing the ladder logic

Write the ladder logic to IB-E04F-FT.

The created ladder logic will not be applied until it has been written.

- 1 Write the ladder logic.
Double-click 'Property' for IB-E04F-FT (Node), for which the ladder logic is to be written, on the project tree window to open the property window.

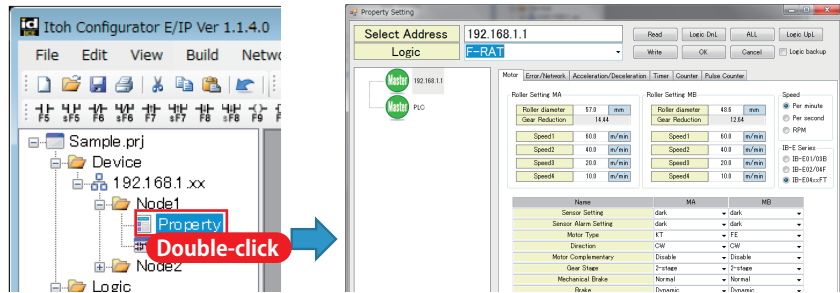

- 2 Select the created logic, and click 'Logic DnL' on the property window.

! When the logic has not been selected (N/A), and "Logic DnL" is clicked, the logic will not be written, or the existing logic for IB-E04F-FT will be deleted.

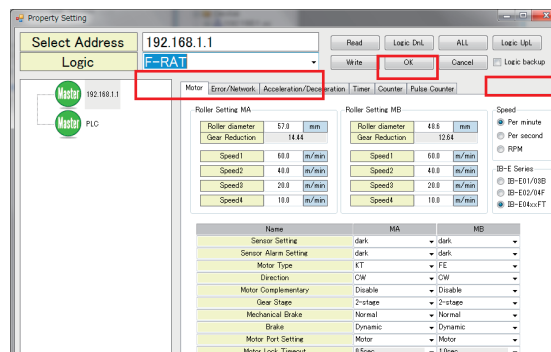

※When writing the ladder logic for reading to the driver card, check 'Logic backup', and click 'Logic DnL'.

Since it takes approximately one or two minutes to write the ladder logic for reading (it depends on the size), we recommend writing only when it is necessary.

- 3 Writing to IB-E04F-FT starts.
When writing succeeds, the "Logic download was successful" message is displayed.
When writing fails, refer to Chapter 4 "4.7 When writing/reading to/from the device fails" in the ICE instruction manual separately.

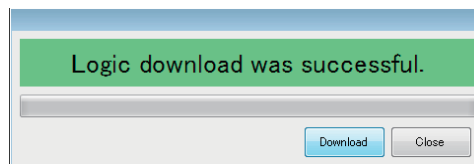

⊘ Do not turn off the power during writing. Also, be sure not to unplug the LAN cable. Failure to follow this could result in malfunction.

✋

- The IB-E04F-FT output will be turned OFF at the time of writing.
- IB-E04F-FT will restart when writing finishes.
- The ladder logic cannot be written when build is not executed.

This completes the ladder logic writing.

Safety precautions

Advance preparation

Product check

Structures

Installation/Wiring

IB-E04F-FT settings

Control/Operation

Maintenance/Inspection

Troubleshooting

Appendix

9. Control/Operation

9-1-1.

Switching the transfer direction

9-1-2.

Changing the speed

Switching the transfer direction

Set the transfer direction with the ladder logic command and 'Direction' under properties.

For details on the ladder logic, refer to "2.4 Ladder logic" (P.2-33) in the ICE instruction manual separately.

Changing the speed

Change the speed with the ladder logic command.

The fourth speed that has been registered in the property settings can be set with the ladder logic.

Change the registered speed in the property settings.

For details on the ladder logic, refer to "2.4 Ladder logic" (P.2-33) in the ICE instruction manual separately.

■ To change the registered speed

- 1 Display the IP address for the corresponding IB-E04F-FT on the project tree window, and open the property window.
- 2 Enter the speed in Speed 1 to 4 on the Motor tab.
- 3 Click "Write" to write the changed speed to IB-E04F-FT.

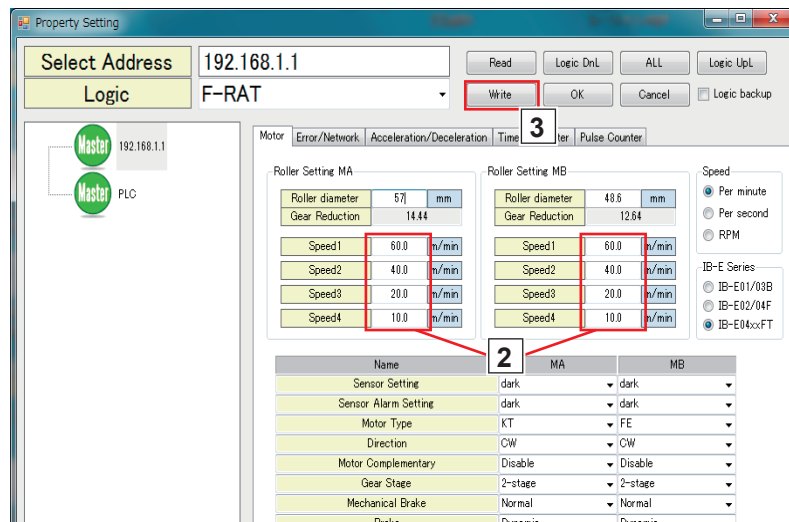

Roller Setting	Category	F-RAT nominal speed	Speed range	Setting STEP
MA	Carrier wheel speed	—	7.7~66.7m/min	Every 1.28m/min
MB	Roller speed	17m/min	2.1~18.3m/min	Every 0.35m/min
		60m/min	7.5~65.0m/min	Every 1.25m/min



- Values out of the speed range cannot be set.
- The speed can be changed for each setting STEP.
- If a speed that does not conform to the setting STEP has been registered, the approximate speed value that conforms to the setting STEP will be adapted. The registered speed (value on the screen) will not be changed.
- "Speed" indicates the value when trays are not placed on carrier wheels and rollers.
- During operation, the rising time to the setting speed may vary depending on ambient temperature. Perform running operation thoroughly.
- Values described above may differ from the actual transfer speed depending on the weight, material, bottom surface, and/or shape of trays, as well as ambient temperature.

9. Control/Operation

9-2.

Basic operation

Introduction



About control

- In this manual, the signal input and output in “9-2. Basic operation” and “9-3. Program example” is described when wiring has been performed based on the wiring example image. When wiring has been performed differently from the wiring example image, IB-E04F-FT signal input and output will vary.
- F-RAT uses MDR for each of carrier wheel transfer, roller transfer, and transfer surface switch (3 MDRs in total). Make sure to control to allow each MDR to run independently.

Wiring example (image)

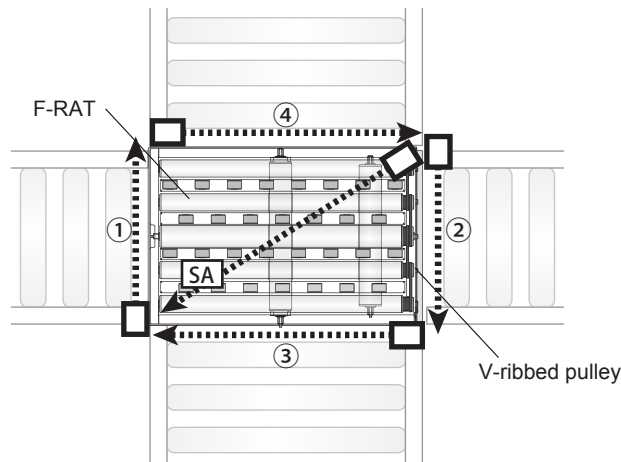

- SA** : F-RAT zone sensor
- ① : Area sensor (on the opposite side of V-ribbed pulley)
- ② : Area sensor (on the side of V-ribbed pulley)
- ③ : Area sensor (on the left side when viewing V-ribbed pulley from the front)
- ④ : Area sensor (on the right side when viewing V-ribbed pulley from the front)

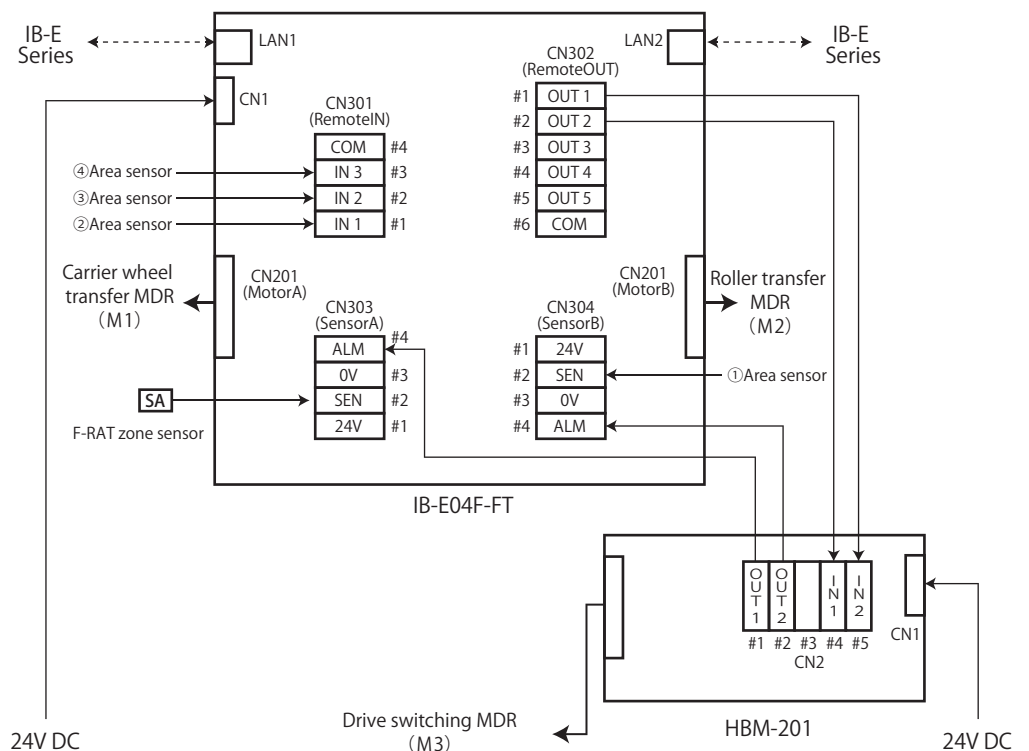

9. Control/Operation

Operation image

Turn on the power

Set the initial position of the transfer surface (Teaching)

Load

Switch the transfer surface to the diverting direction (Roller transfer → Carrier wheel transfer)

Discharge

Prepare reception (Transfer surface switch) (Carrier wheel transfer → Roller transfer)

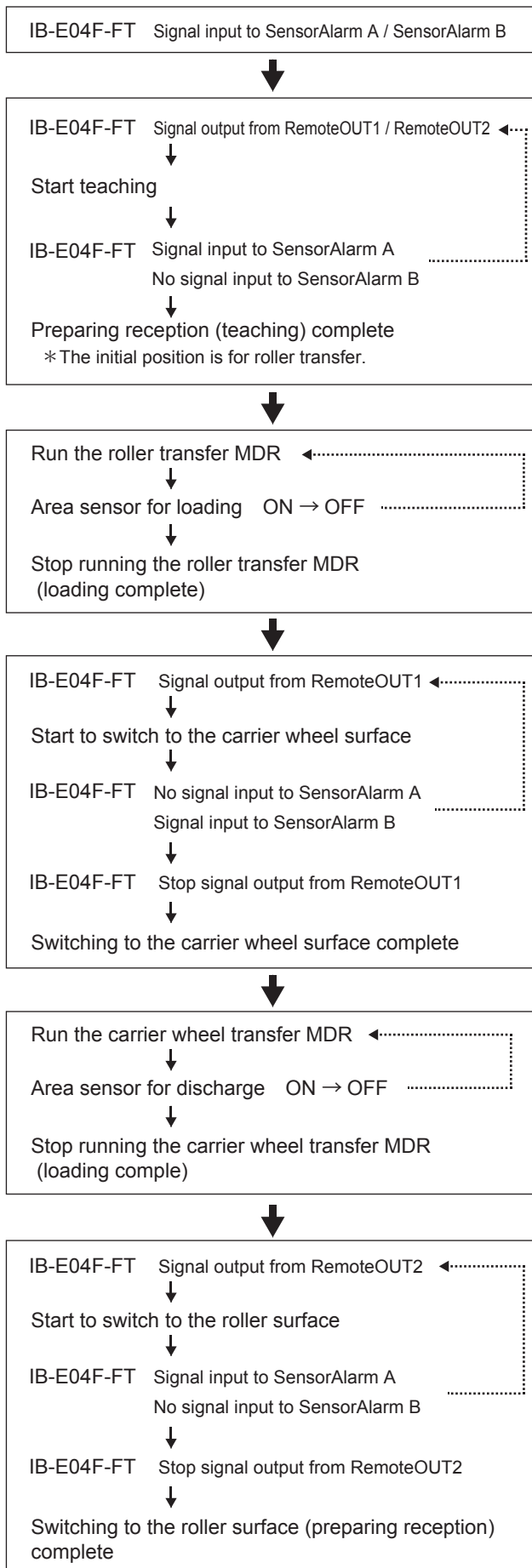
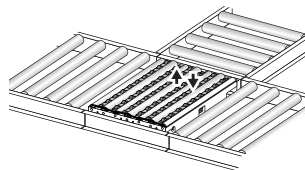
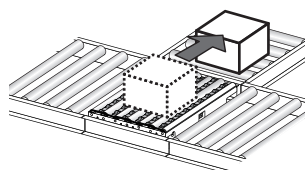
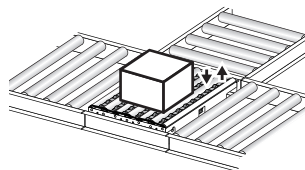
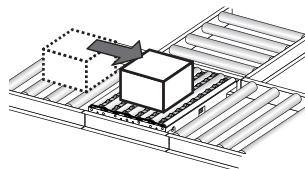

Safety precautions

Advance preparation

Product check

Structures

Installation/Wiring

IB-E04F-FT settings

Control/Operation

Maintenance/Inspection

Troubleshooting

Appendix

9. Control/Operation

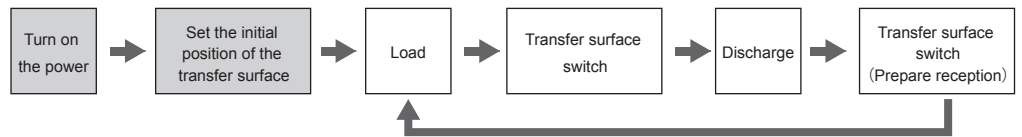

The following operation is when MA/MB of IB-E04F-FT is set to RUN, and the transfer direction is set to CCW. The load and discharge directions will vary depending on the property settings and ladder logic programming method. [Refer to 9-1-1. Switching the transfer direction on P.58]

Transfer flow chart (when using the roller for loading, and carrier wheel for discharging)

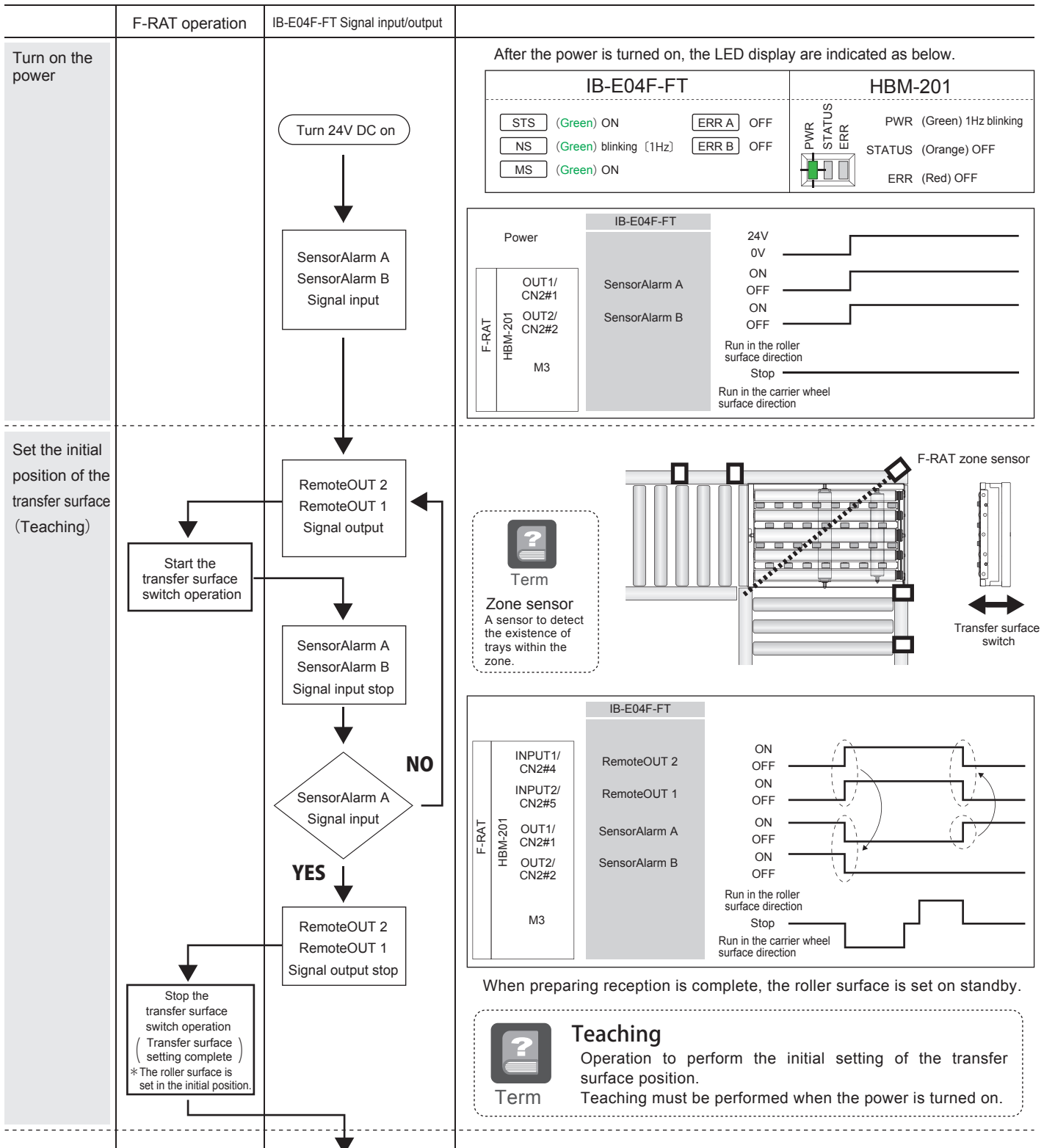

Safety precautions

Advance preparation

Product check

Structures

Installation/Wiring

IB-E04F-FT settings

Control/Operation

Maintenance/Inspection

Troubleshooting

Appendix

9. Control/Operation

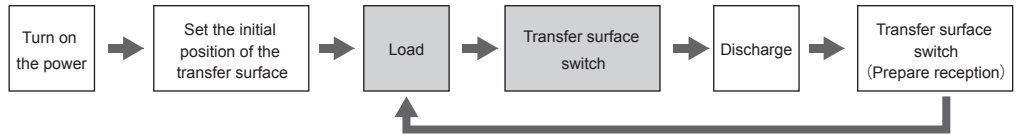

	F-RAT operation	IB-E04F-FT Signal input/output																																																										
Load																																																												
				<table border="1"> <thead> <tr> <th colspan="2"></th> <th>IB-E04F-FT</th> <th></th> <th></th> </tr> </thead> <tbody> <tr> <td rowspan="2">Load conveyor MDR</td> <td>-</td> <td>RUN</td> <td>ON</td> <td>ON</td> </tr> <tr> <td>-</td> <td>STOP</td> <td>OFF</td> <td>OFF</td> </tr> <tr> <td rowspan="2">Zone sensor for the load conveyor</td> <td>-</td> <td>ON</td> <td>ON</td> <td>ON</td> </tr> <tr> <td>-</td> <td>OFF</td> <td>OFF</td> <td>OFF</td> </tr> <tr> <td rowspan="2">③Area sensor</td> <td>RemoteIN 2</td> <td>ON</td> <td>ON</td> <td>ON</td> </tr> <tr> <td>SensorA_SEN</td> <td>OFF</td> <td>OFF</td> <td>OFF</td> </tr> <tr> <td rowspan="2">F-RAT zone sensor</td> <td>M1</td> <td>MA</td> <td>ON(RUN)</td> <td>ON</td> </tr> <tr> <td>M2</td> <td>MB</td> <td>OFF(STOP)</td> <td>OFF</td> </tr> <tr> <td rowspan="2">F-RAT HBM-201</td> <td>INPUT1/ CN2#4</td> <td>RemoteOUT 2</td> <td>ON</td> <td>ON</td> </tr> <tr> <td>INPUT2/ CN2#5</td> <td>RemoteOUT 1</td> <td>OFF</td> <td>OFF</td> </tr> <tr> <td></td> <td>OUT1/ CN2#1</td> <td>SensorAlarm A</td> <td>ON</td> <td>ON</td> </tr> <tr> <td></td> <td>OUT2/ CN2#2</td> <td>SensorAlarm B</td> <td>OFF</td> <td>OFF</td> </tr> </tbody> </table>			IB-E04F-FT			Load conveyor MDR	-	RUN	ON	ON	-	STOP	OFF	OFF	Zone sensor for the load conveyor	-	ON	ON	ON	-	OFF	OFF	OFF	③Area sensor	RemoteIN 2	ON	ON	ON	SensorA_SEN	OFF	OFF	OFF	F-RAT zone sensor	M1	MA	ON(RUN)	ON	M2	MB	OFF(STOP)	OFF	F-RAT HBM-201	INPUT1/ CN2#4	RemoteOUT 2	ON	ON	INPUT2/ CN2#5	RemoteOUT 1	OFF	OFF		OUT1/ CN2#1	SensorAlarm A	ON	ON	
		IB-E04F-FT																																																										
Load conveyor MDR	-	RUN	ON	ON																																																								
	-	STOP	OFF	OFF																																																								
Zone sensor for the load conveyor	-	ON	ON	ON																																																								
	-	OFF	OFF	OFF																																																								
③Area sensor	RemoteIN 2	ON	ON	ON																																																								
	SensorA_SEN	OFF	OFF	OFF																																																								
F-RAT zone sensor	M1	MA	ON(RUN)	ON																																																								
	M2	MB	OFF(STOP)	OFF																																																								
F-RAT HBM-201	INPUT1/ CN2#4	RemoteOUT 2	ON	ON																																																								
	INPUT2/ CN2#5	RemoteOUT 1	OFF	OFF																																																								
	OUT1/ CN2#1	SensorAlarm A	ON	ON																																																								
	OUT2/ CN2#2	SensorAlarm B	OFF	OFF																																																								
Transfer surface switch																																																												
				<table border="1"> <thead> <tr> <th colspan="2"></th> <th>IB-E04F-FT</th> <th></th> <th></th> </tr> </thead> <tbody> <tr> <td rowspan="2">F-RAT zone sensor</td> <td>SensorA_SEN</td> <td>ON</td> <td>ON</td> <td>ON</td> </tr> <tr> <td></td> <td>OFF</td> <td>OFF</td> <td>OFF</td> </tr> <tr> <td rowspan="2">M1</td> <td>MA</td> <td>ON(RUN)</td> <td>ON</td> <td>ON</td> </tr> <tr> <td></td> <td>OFF(STOP)</td> <td>OFF</td> <td>OFF</td> </tr> <tr> <td rowspan="2">M2</td> <td>MB</td> <td>ON(RUN)</td> <td>ON</td> <td>ON</td> </tr> <tr> <td></td> <td>OFF(STOP)</td> <td>OFF</td> <td>OFF</td> </tr> <tr> <td rowspan="2">F-RAT HBM-201</td> <td>INPUT1/ CN2#4</td> <td>RemoteOUT 2</td> <td>ON</td> <td>ON</td> </tr> <tr> <td>INPUT2/ CN2#5</td> <td>RemoteOUT 1</td> <td>OFF</td> <td>OFF</td> </tr> <tr> <td></td> <td>OUT1/ CN2#1</td> <td>SensorAlarm A</td> <td>ON</td> <td>ON</td> </tr> <tr> <td></td> <td>OUT2/ CN2#2</td> <td>SensorAlarm B</td> <td>OFF</td> <td>OFF</td> </tr> </tbody> </table>			IB-E04F-FT			F-RAT zone sensor	SensorA_SEN	ON	ON	ON		OFF	OFF	OFF	M1	MA	ON(RUN)	ON	ON		OFF(STOP)	OFF	OFF	M2	MB	ON(RUN)	ON	ON		OFF(STOP)	OFF	OFF	F-RAT HBM-201	INPUT1/ CN2#4	RemoteOUT 2	ON	ON	INPUT2/ CN2#5	RemoteOUT 1	OFF	OFF		OUT1/ CN2#1	SensorAlarm A	ON	ON		OUT2/ CN2#2	SensorAlarm B	OFF	OFF					
		IB-E04F-FT																																																										
F-RAT zone sensor	SensorA_SEN	ON	ON	ON																																																								
		OFF	OFF	OFF																																																								
M1	MA	ON(RUN)	ON	ON																																																								
		OFF(STOP)	OFF	OFF																																																								
M2	MB	ON(RUN)	ON	ON																																																								
		OFF(STOP)	OFF	OFF																																																								
F-RAT HBM-201	INPUT1/ CN2#4	RemoteOUT 2	ON	ON																																																								
	INPUT2/ CN2#5	RemoteOUT 1	OFF	OFF																																																								
	OUT1/ CN2#1	SensorAlarm A	ON	ON																																																								
	OUT2/ CN2#2	SensorAlarm B	OFF	OFF																																																								

Safety precautions
Advance preparation
Product check
Structures
Installation/Wiring
IB-E04F-FT settings
Control/Operation
Maintenance/Inspection
Troubleshooting
Appendix

9. Control/Operation

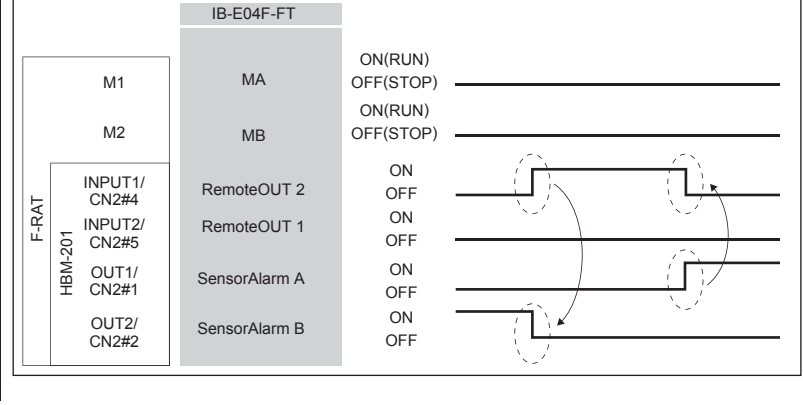
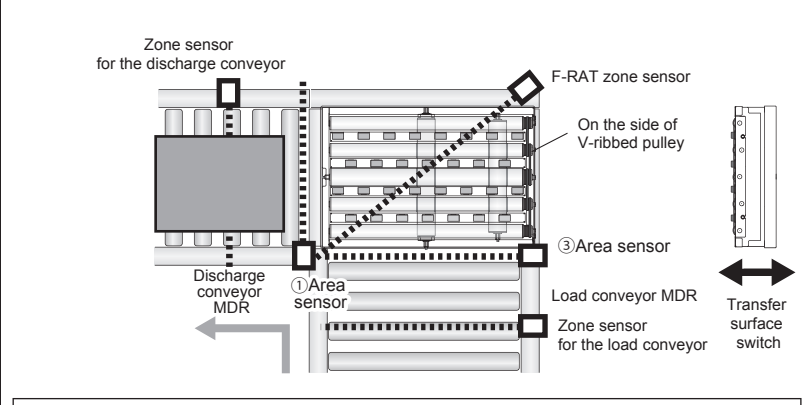
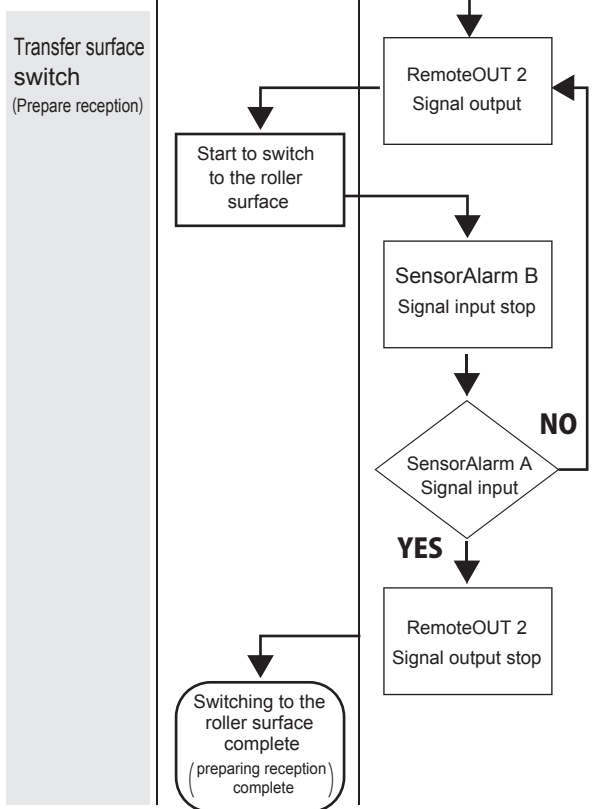
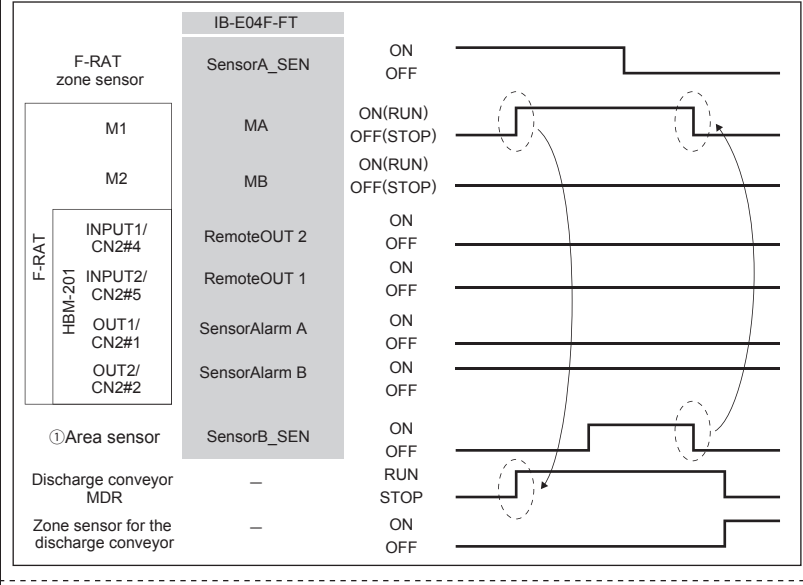
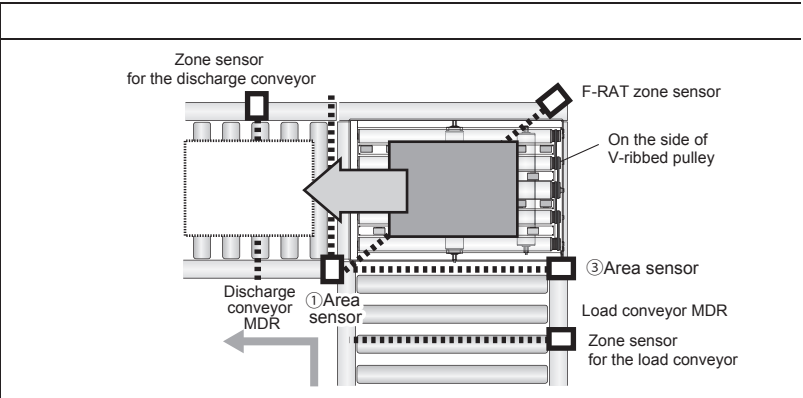
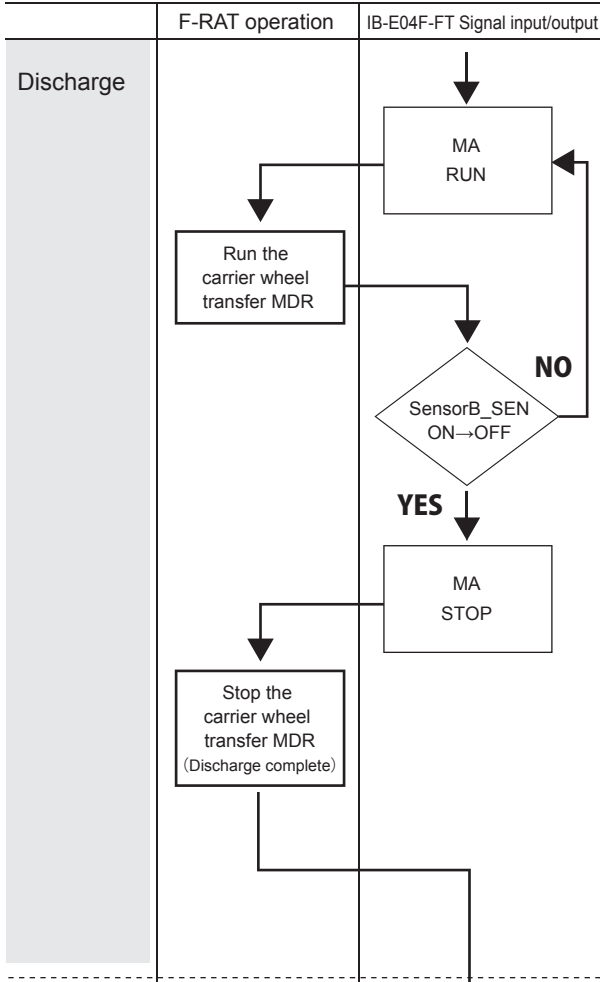
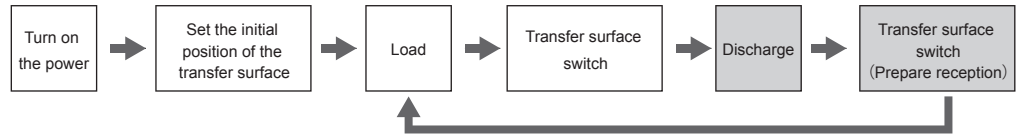

Safety precautions

Advance preparation

Product check

Structures

Installation/Wiring

IB-E04F-FT settings

Control/Operation

Maintenance/Inspection

Troubleshooting

Appendix

9. Control/Operation

9-2-1. Switching the transfer surface

(M3:HBM-201)

Roller transfer → Carrier wheel transfer

Refer to CN2

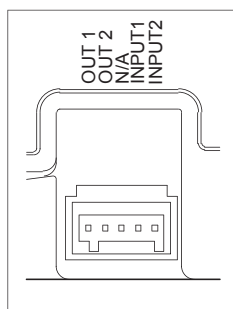

Carrier wheel transfer → Roller transfer

Refer to CN2

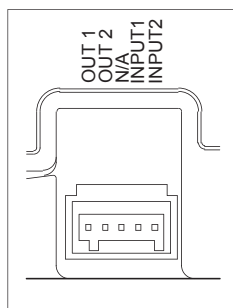

Switching the transfer surface

Use HBM-201 to switch the transfer surface.

The transfer surface can be switched by inputting the signal to CN2#4 and CN2#5.



After the initial position setting (teaching) of the transfer surface, the roller surface is put on standby. To put the carrier wheel surface on standby (use it for reception), the transfer surface needs to be changed by the signal input. Refer to 9-2-2. About the initial position setting (teaching) of the transfer surface (P.65)

Roller transfer → Carrier wheel transfer

PLC	HBM-201 (M3)			
Output	CN2#4	INPUT1 (Roller surface switch input)	ON OFF	
Output	CN2#5	INPUT2 (Carrier wheel surface switch input)	ON OFF	
Input	CN2#1	OUT1 (Roller surface standby output)	ON OFF	
Input	CN2#2	OUT2 (Carrier wheel surface standby output)	ON OFF	

Run in the roller surface direction
M3 : Drive switching MDR Stop

Run in the carrier wheel surface direction

PWR STATUS ERR	Transfer surface status	Roller	Roller → Carrier Wheel	Carrier Wheel
	PWR [Green]	ON	3Hz × 2 ↓ OFF	ON
	STATUS [Orange]	ON	OFF	ON
	ERR [Red]	OFF	OFF	OFF

Carrier wheel transfer → Roller transfer

PLC	HBM-201 (M3)			
Output	CN2#4	INPUT1 (Roller surface switch input)	ON OFF	
Output	CN2#5	INPUT2 (Carrier wheel surface switch input)	ON OFF	
Input	CN2#1	OUT1 (Roller surface standby output)	ON OFF	
Input	CN2#2	OUT2 (Carrier wheel surface standby output)	ON OFF	

Run in the roller surface direction
M3 : Drive switching MDR Stop

Run in the carrier wheel surface direction

PWR STATUS ERR	Transfer surface status	Carrier Wheel	Carrier Wheel → Roller	Roller
	PWR [Green]	ON	3Hz × 3 ↓ OFF	ON
	STATUS [Orange]	ON	OFF	ON
	ERR [Red]	OFF	OFF	OFF



If the signal input stops when the transfer surface is being switched, operation will be interrupted, and the signal output from both CN2#1 and #2 will stop. When inputting the signal again, operation restarts.

安全上のご注意

事前準備

製品の確認

各部名称

設置・配線

I B E O 4 F T の設定

制御・運転

保守点検

故障かなと思つたら

付録

9. Control/Operation

9-2-2.

About the initial position setting (teaching) of the transfer surface

[M3:HBM-201]

Teaching operation

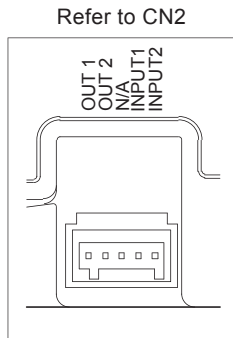

About the initial position setting (teaching) of the transfer surface

The initial position setting (teaching) of the transfer surface is necessary to set the transfer surface after the power is turned on.

To perform teaching, use HBM-201.



- If teaching has not been set, the transfer surface cannot be switched.
- During teaching operation, do not load trays on the F-RAT.
- When teaching fails, both CN2#1(OUT1)(roller surface status output) and CN2#2(OUT2)(carrier wheel status output) are turned ON, which is the same status as when the power is turned on. In such cases, perform teaching operation again.

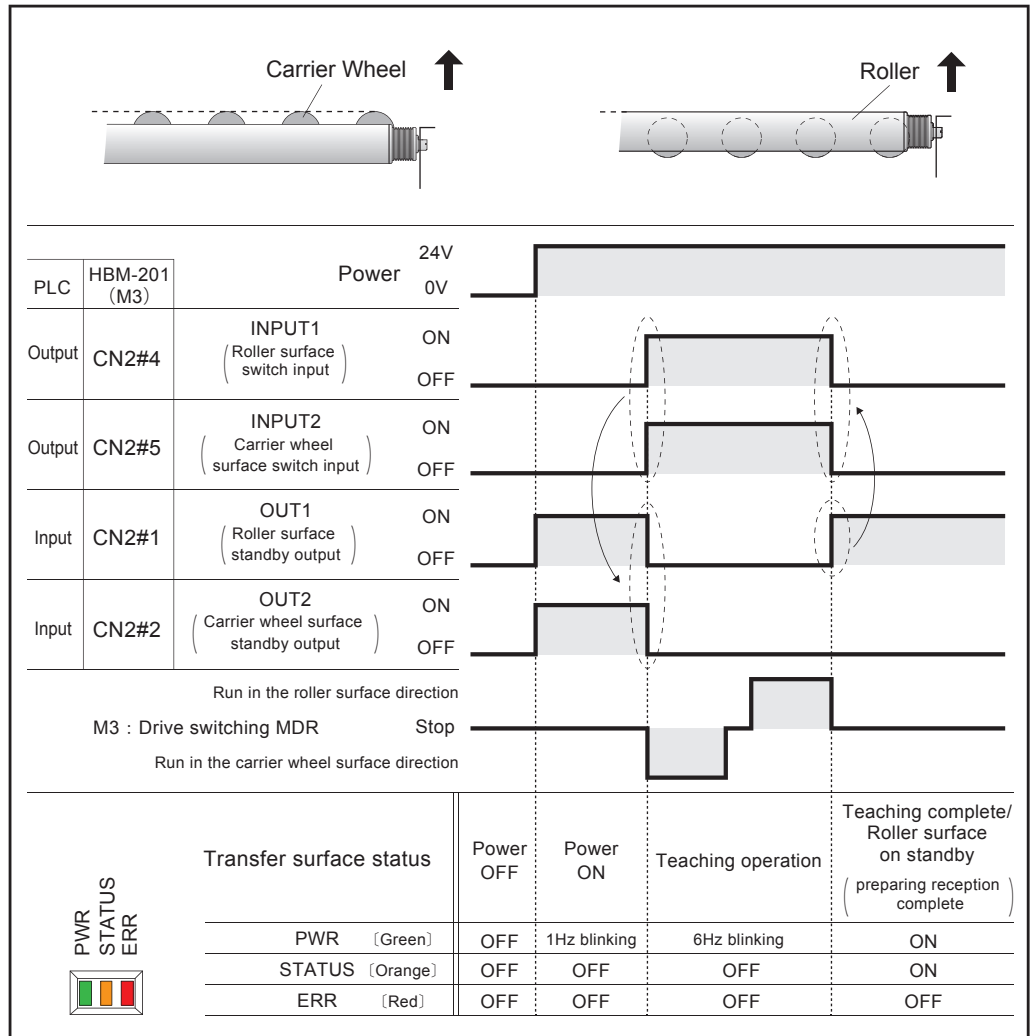

Teaching

Operation to perform the initial setting of the transfer surface position. After the power is turned on, perform teaching by inputting signal from the driver card.

Term

安全上のご注意

事前準備

製品の確認

各部名称

設置・配線

I B E O 4 F T の設定

制御・運転

保守点検

故障かなと思つたら

付録

9. Control/Operation

9-3.

Program example

Operation by loading through roller transfer and discharging through carrier wheel transfer

Basic operation (example)

Program example



Do not load trays from the roller transfer MDR direction while the carrier wheel status is output (signal input to SensorAlarm B on IB-E04F-FT). Failure to follow this could result in damage to trays, and malfunction.

The following time chart is an example.

When in use, control the number of sensors, and/or determine how to place/control sensors depending on your operation.

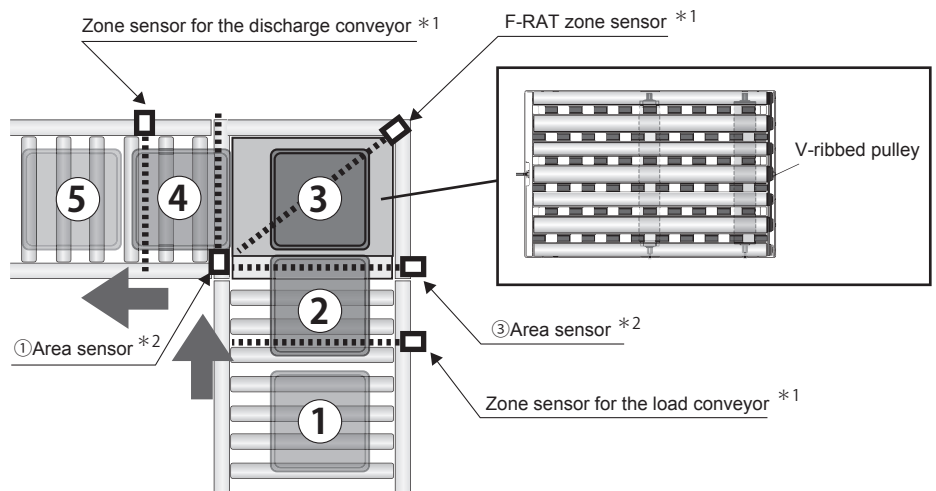
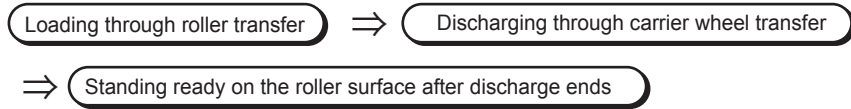

Time chart example

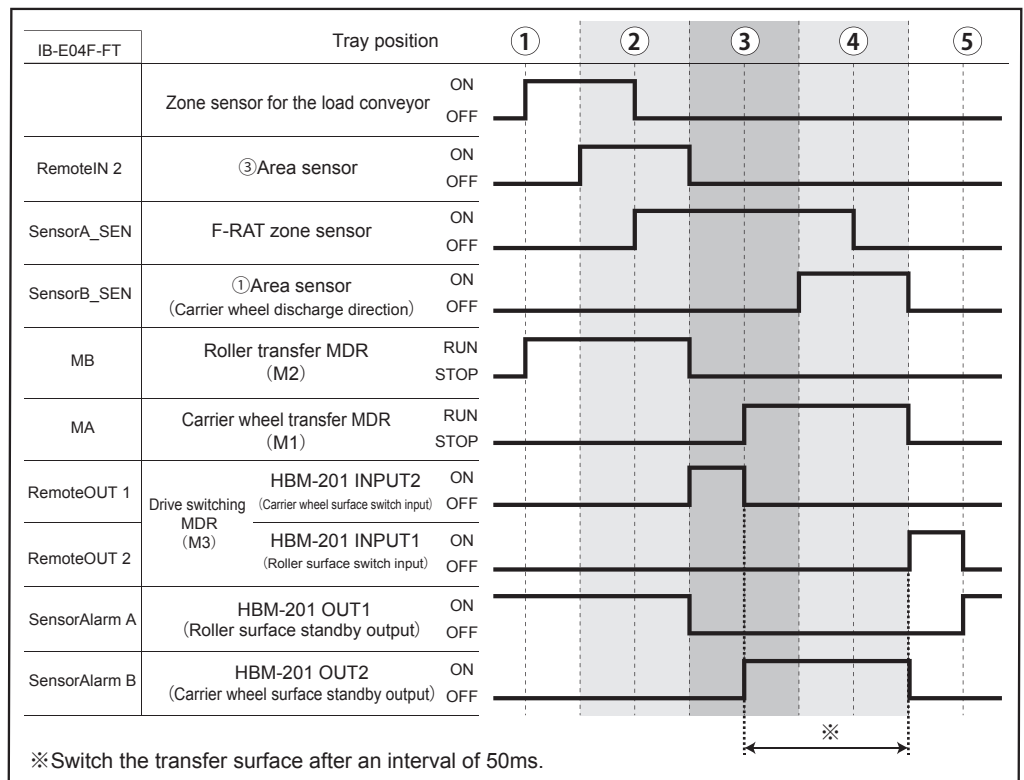

Term

*1 Zone sensor

A sensor to detect the existence of trays within the zone

*2 Area sensor

A sensor to detect load and discharge of trays

9. Control/Operation

9-4. What to do before operation

Start-up inspection

To prevent accidents and/or damage to devices during operation, refer to the below before operation, and check the safety.

Items to check before turning on the power

Turn off the power of all connected devices, and perform the following inspection, taking necessary measures.

-  Turn off the power, wait a sufficient amount of time, and discharge electricity inside the DC power supply equipment.
- Post warning labels so as to prevent unauthorized persons from turning on the power.

Parts to be inspected	Inspection items	Description of measures
Secured positions of the F-RAT main unit	Screw looseness	Re-tighten screws
Driver card	Damage, deformation	Contact the supplier
	Screw looseness on secured positions	Re-tighten screws
	Mounting failure for driver cards and connectors	Correctly mount connectors
	Damage to cables/Wiring failure	Perform wiring correctly
Idler for roller transfer	External abnormalities, such as scratches or breakage	Refer to P.76 <u>10-3. Before replacement work</u>
Roller transfer MDR	External abnormalities, such as scratches, dents, or breakage	
Roller drive belt for roller transfer	Cracks, looseness, wear on the surface	
Carrier wheel	Cracks, wear on the surface	
Others	Parts deformation, damage	Contact the supplier
	Cable damage	

Items to check after turning on the power

Manually input the signal to driver cards according to inspection contents.

-  Perform inspection after completing measures to prevent fingers from getting stuck and/or caught in rollers during transfer switching, and/or transfer operation.
- Take safety measures, such as getting ready to shut off the power in the event that something should happen.

Parts to be inspected	Inspection items	Description of measures
Driver card	Error check with LED display <Normal LED display after the power is turned on> ●IB-E04F-FT [STS] (Green) ON [PWR] (Green) Blinking [1Hz] [NS] (Green) Blinking [1Hz] [ERR] (Red) OFF [MS] (Green) ON [ERR A] OFF [ERR B] OFF ●HBM-201	Check error contents, and eliminate the causes. ※For driver card LED display and error countermeasures, refer to <u>10-1. LED indication (P.70).</u>
Idler for roller transfer	Abnormal sound Rotation failure	Refer to P.76 <u>10-3. Before replacement work</u>
Roller transfer MDR	Abnormal sound Decrease from the specified speed Abnormal temperature rise	
Carrier wheel transfer MDR	Abnormal sound Decrease from the specified speed Abnormal temperature rise (Check ERR LED on driver cards)	Contact the supplier
Drive switching MDR	Abnormal sound Abnormal temperature rise (Check ERR LED on driver cards)	
Others	Leakage from equipment	Check grounding on equipment, perform grounding

9. Control/Operation

Trial run

■ Items to check before the trial run

Check below before the trial run.

- When the roller transfer MDR and/or idlers have been replaced, check that the drive belts have been mounted in the correct groove positions.
- Check all parts are installed.

■ Performing the trial run

When the start-up inspection has finished, perform the trial run with careful attention to the following points, and check that operation is correctly performed.



- Prevent other devices around the product from operating.
Other devices incorporated in the system, such as conveyor lines, could create dangerous situations, since trays may start to flow from upstream when the trial run is driven.
Check carefully that other elements in the system will not operate when the product starts running.
- Make sure to check that wiring, driver card settings, and PLC settings have been carried out correctly before the trial run.
- During operation, the transfer speed may not reach the specified value depending on ambient temperature.
When the carrier wheel cassette has been replaced, perform running operation thoroughly to eliminate any bends from belts.

10. Maintenance/Inspection

10-1. LED indication	70
10-2. Checking and releasing errors	74
10-3. Before replacement work	76
10-4. Replacement of MDR for roller transfer/idlers/roller drive belts	78
10-5. Replacement of the carrier wheel cassette	83

10. 保守点検

10-1. LED indication

If errors occur with this product, identify the causes of errors by checking LEDs and error signals on the driver card/controller, and perform recovery work.

IB-E04F-FT
For carrier wheel transfer
For roller transfer

IB-E04F-FT

LED indication is found at the following locations.

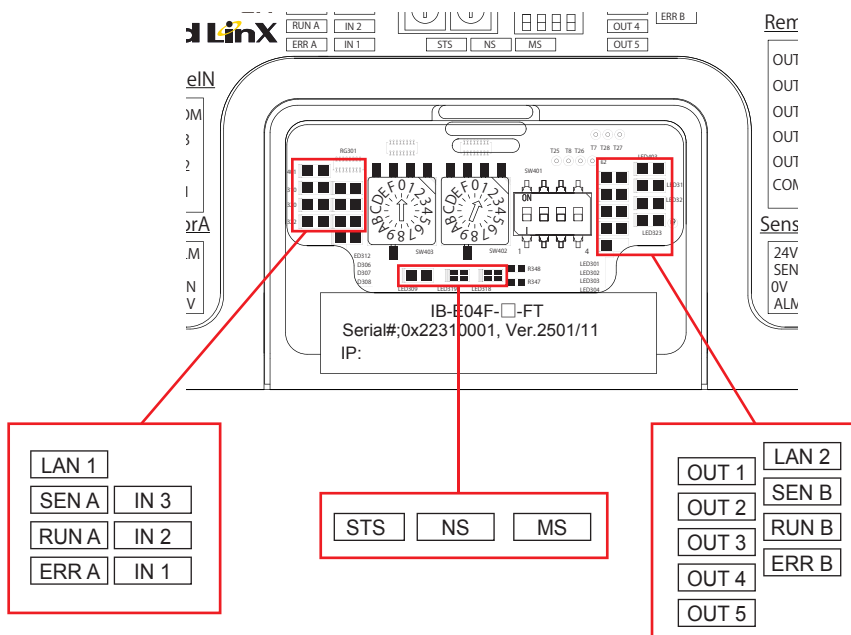

10. Maintenance/Inspection

● LED indication

LED type	LED indication pattern	Description
MS LED MS	OFF	Power OFF on the communication PCB (*1)
	ON (Green)	Normal startup
	ON (Green) ⇔ Blinking(1 Hz)(Red)	Device (IP address, etc.) has not been specified
	Blinking(1 Hz)(Red)	Communication error (LAN1 or LAN2 port)
	ON (Red)	Communication error (LAN1 and LAN2 ports)
	Blinking(1 Hz)(Green) ⇔ Blinking(1 Hz)(Red)	At the time of startup settings (when the power is turned ON)
NS LED NS	OFF	No communication
	Blinking(1 Hz)(Green)	Normal startup (IP address obtained normally)
	ON (Green)	I/O connection has been set
	Blinking(1 Hz)(Red)	I/O connection timeout
	ON (Red)	IP address overlap
	Blinking(1 Hz)(Green) ⇔ Blinking(1 Hz)(Red)	At the time of startup settings (when the power is turned ON)
STS LED STS	ON (Green)	Power ON on the communication PCB
	Blinking(6 Hz)(Green)	Low voltage error
	Blinking(1 Hz)(Green)	When the firmware is being changed
	OFF	Power OFF on the communication PCB
LAN LED LAN 1 LAN 2	Blinking(Green)	During communication
	OFF	No communication
Sensor LED SENA SEN B	ON (Green)	With sensor input (*2)
	OFF	Without sensor input
Remote IN LED IN 1 IN 2 IN 3	ON (Green)	With remote input (*2)
	OFF	Without remote input
Remote OUT LED OUT 1 OUT 2 OUT 3 OUT 2 OUT 3	ON (Green)	With remote output (*2)
	OFF	Without remote output
RUN LED RUN A RUN B	Refer to the error list	
ERR LED ERRA ERR B		

(*1) MS LED is also OFF when the rotary switch (SW402, SW403) is "00".

(*2) Sensor LED, Remote_IN LED, and Remote_OUT LED1 will also be turned ON when initialization is complete on IB-E04F-FT.

10. Maintenance/Inspection

● Error details

The table below describes the LED indication when an error occurs, occurrence conditions, and release conditions, as well as the ladder logic and MDR status during error generation.

Use ICE to check errors, and release errors manually.

Refer to (10-2. Checking and releasing errors)

Type of error	Priority (※1)	LAN LED	ERR LED	Status/ Error occurrence conditions	Error release conditions (※2)	Type of error release	Ladder logic	MDR
		OFF	OFF	When MDR stops (No error)			Operation	Stop
		ON	OFF	When MDR rotates, or at the time of motor port output			Operation	Operation
Under Voltage Error	1	STS LED Blinking(6Hz)		Power supply voltage is less than 20 V	Set the power supply voltage to 24V DC±10%	Automatic	Stop	Stop
Fuse blown error	1	OFF	Blinking (6Hz)	Controller fuse blown	Cannot be released (※3)	—	Operation	Stop
Motor Disconnected	2	OFF	Blinking (1Hz)	Motor connector disconnected	Turn off the power, and connect the connector	Automatic /Manual	Operation	Stop
Motor Lock	3	ON	Blinking (1Hz)	Hall signal keeps unchanged (Carrier wheel transfer MDR: 0.5sec., Roller transfer MDR: 1sec.)	Automatic release: Release command from the pulse change upper level Manual release: Release command from the upper level	Automatic /Manual	Operation	Stop
PCB Thermal	4	OFF	ON	PCB temperature has exceeded the threshold value for 1sec.	Set PCB temperature to the threshold value or less	Automatic /Manual	Operation	Stop
Motor Thermal	5	OFF	ON	Motor temperature has exceeded the threshold value for 1sec.	Set motor temperature to the threshold value or less	Automatic /Manual	Operation	Stop
Back EMF Error	6	ON	Blinking (twice at 6Hz with 1.7S cycle)	Inductive voltage has been 40V or more for 2sec., or has been 60V or more for 0.1sec.	Supply a voltage of 24V DC±10%	Manual	Operation	Stop
Motor Port current limit	6			Motor port current has been 4A or more for 0.1sec.	Set motor port current less than 4A	Manual	Operation	Stop
Jam Error	7	Blinking alternately 1HZ	Blinking alternately 1HZ	Output coils Y22 and Y23 are turned ON	Turn output coils Y22 and Y23 OFF	Ladder	Operation	Operation
Sensor Timer Error	8	Blinking alternately 6HZ	Blinking alternately 6HZ	Output coils Y29 and Y30 are turned ON	Turn output coils Y29 and Y30 OFF	Ladder	Operation	Operation

(※1) If multiple errors occur at the same time, the LED indication will be selected based on the highest priority error.

In addition, when releasing an error during multiple error generation, lower priority errors than the error that has been released will also be released.

Note that if any factors for lower priority errors remain after error release, an error will occur again.

(※2) In manual error release, when error release conditions are satisfied, release the error by the error release command from the upper level.

To release errors manually, use the Error Information window on ICE.

(Refer to Chapter 2 "2.6.2.2 Releasing the error manually" in the ICE instruction manual separately.)

(※3) There is no error release procedure for the fuse blown error. Replace IB-E04F-FT.

10. Maintenance/Inspection

[HBM-201]
For drive switching

Even if inputting the signal to CN2#4 and #5, but the signal output from CN2#1 and #2 does not change, the following errors have been assumed to occur. Errors can be distinguished by the LED display.

LED display explanation

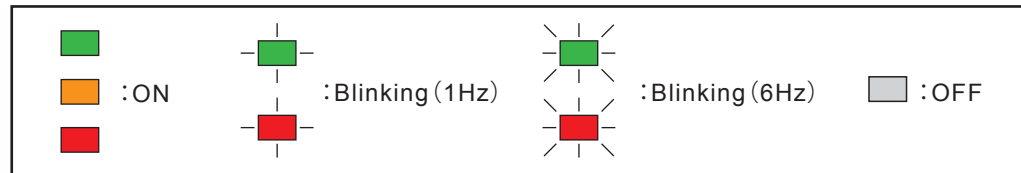

Error details

PWR (green)	ERR (Red)	Description	Causes	Recovery conditions	Recovery operation
		Stop (signals not input)	(Normal operation)	-	-
3Hz blinking × 2 ⇕ OFF for 480ms		When wheel surface transfer is effected (Signal is being input to CN2#5)			
3Hz blinking × 3 ⇕ OFF for 480ms		When roller surface transfer is effected (Signal is being input to CN2#4)			
		During teaching operation (Signal is being input to CN2#4 and CN2#5)			
		No teaching setting	Teaching setting incomplete	Teaching setting complete	Refer to P.65 9-2-2. About the initial position setting (teaching) of the transfer surface
*		Thermal error	Driver card temperature is 85°C or more, or MDR temperature is 110°C or more	Driver card temperature is 75°C or less, and MDR temperature is 95°C or less	Take one of among the following measures: • IB-E04F-FT RemoteOUT1 OFF → ON • IB-E04F-FT RemoteOUT2 OFF → ON • IB-E04F-FT RemoteOUT1 and RemoteOUT2 OFF → ON
*		MDR disconnected	MDR connectors removed	Connect the MDR connectors	
*		Lock error	MDR has been locked when switching the transfer surface	Eliminate the cause of lock	
		Low voltage error	The voltage has been 17 V or less for 1sec, or the power connector is connected improperly	Supply a voltage of 24V DC ±10%, or properly connect the power connector again	
		Fuse blown	Driver card fuse blown	Replace the driver card	Refer to P.37 Mounting driver cards

* Indicates the signal input status during normal operation.

STATUS (Orange) details

STATUS (Orange)	Description
	No teaching setting / During teaching operation / When the transfer surface is being switched
	Roller surface standby / Carrier wheel surface standby

10. Maintenance/Inspection

10-2. Checking and releasing errors

Use ICE to check error status, and release errors manually.



■ To release an error on HBM-201, use RemoteOUT on IB-E04F-FT. (Refer to HBM-201 error details)

Checking error status

- 1 Select 'Dialog' - 'Error Information' from the main menu.

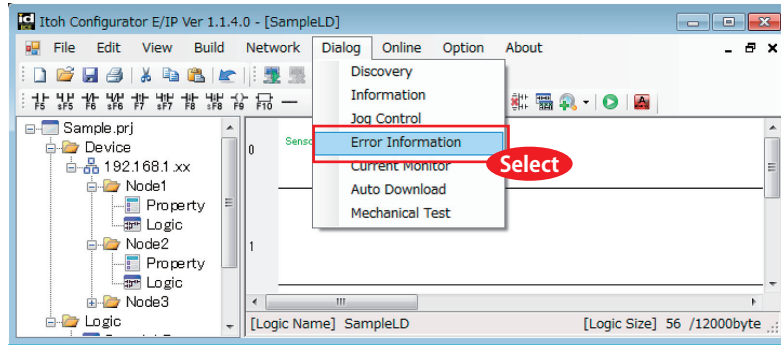

- 2 Select the IP Address for the PC used to open ICE, and click 'OK'.

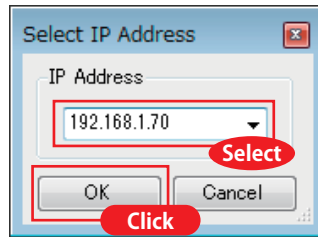

- 3 The Error Information window is displayed as shown below. The current error status on the IB are displayed on this window.

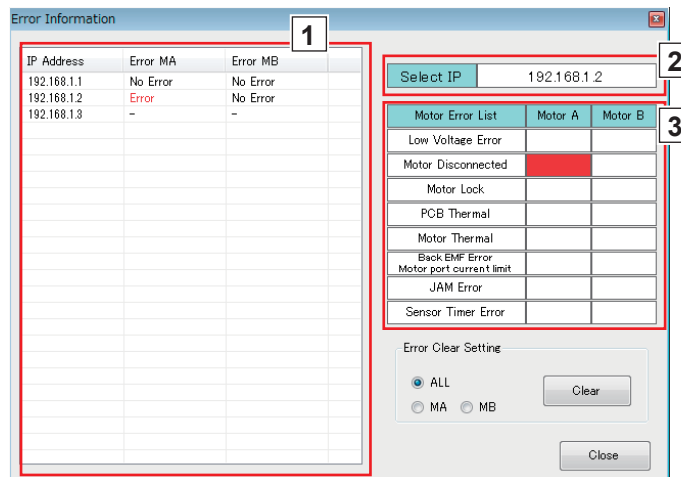

- 1 Error Information window
Whether or not errors occur on the connected controller is displayed collectively. "No Error" is displayed for the MDR where no error occurs, "Error" for the MDR where an error occurs, and "-" for IBs that have not been connected.
- 2 The IP address for the selected controller is displayed.
To specify other controllers, click an optional IP address on ① to switch to the controller with the selected IP address.
- 3 The error status for the controller selected in ② is displayed.
The error status for the selected controller is displayed in Motor Error List. Error items for axes where errors occur will turn red.

10. Maintenance/Inspection

Releasing the error manually

Click 'Clear' on the Error Information window to release the error.

- 1 Specify the IP address for the controller where the error is to be released to display the selected IP address in SelectIP.
(The error status for the selected controller is displayed in Motor Error List)
- 2 Select the MDR of which error is to be released under "Error Clear Setting", and click 'Clear'.

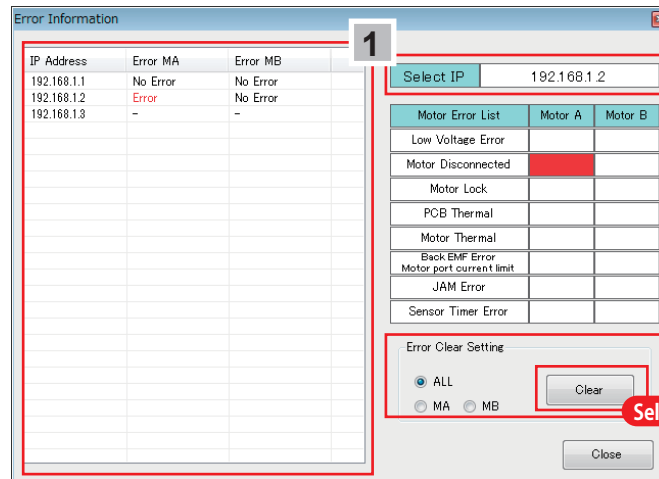

10. Maintenance/Inspection

10-3. Before replacement work

If any abnormalities, such as damaged parts, are found, immediately take actions, including replacement with new parts.

- Check the model of this product, and prepare parts to be replaced with in advance.
- Contact us for repair/replacement of parts other than those mentioned below.

Product label



Replacement parts list

Carrier wheel cassette

Part number : NX75-CC□□○-HD1

□□ : 60 / 75 / 90 ○ : A / B / C / D / E

Indicates size (L direction) for the model of this product. Indicates type of the cassette.

Example) F-RAT-NX75-F60-7550-EN

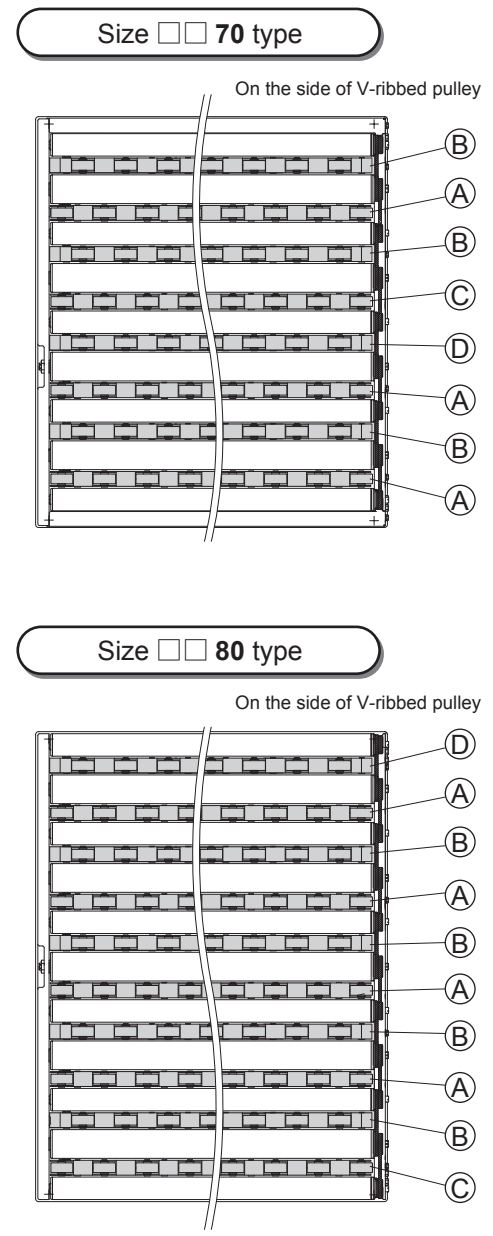
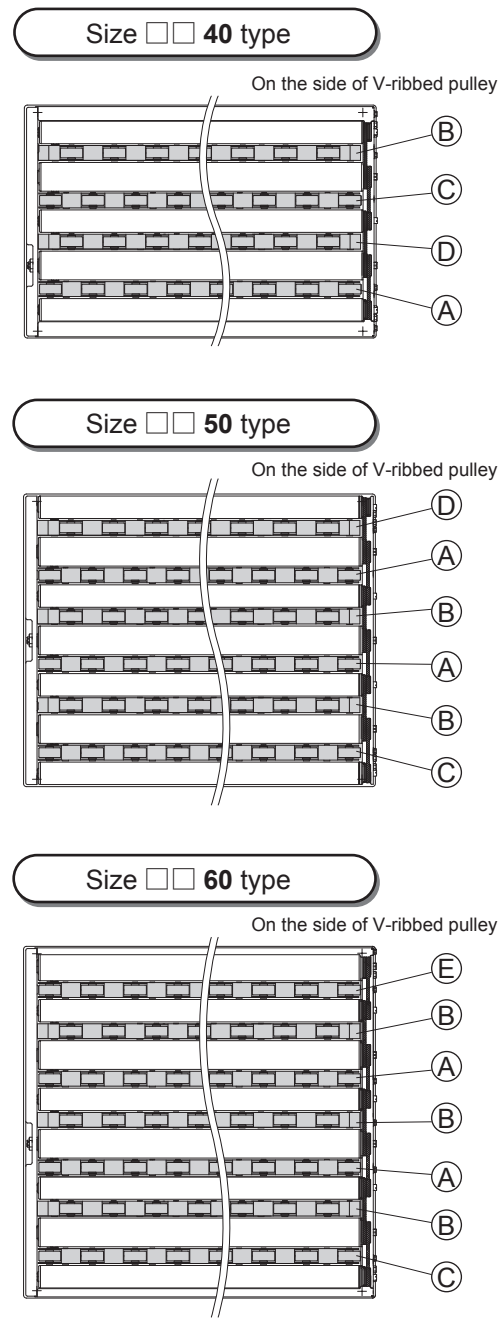

Example) Carrier wheel cassette Type **Ⓑ** for F-RAT-NX75-F60-7550-EN-S3 : NX75-CC-75**Ⓑ**-HD1

10. Maintenance/Inspection

Roller drive belt
(V-ribbed belt)

Part number : 2PJ-265

The part number of which only belts, size □□60 *¹ type, are used to link Φ38 idlers, is 2PJ-246.

* 1 Indicates size (W direction) for the model of this product
Example) F-RAT-NX75-F60-7560-EN-S3

Roller transfer MDR

Size 60 * ¹ □□	PM486FE-(17/60)* ² -542-D-024-JA-Z150-VN
Size 75 * ¹ □□	PM486FE-(17/60)* ² -692-D-024-JA-Z150-VN
Size 90 * ¹ □□	PM486FE-(17/60)* ² -842-D-024-JA-Z150-VN

* 1 Indicates size (L direction) for the model of this product
Example) F-RAT-NX75-F60-7550-EN-S3
* 2 Indicates the nominal speed for the model of this product
Example) F-RAT-NX75-F60-7550-EN-S3

Idler

Size 60 * ¹ □□	φ 38	ARI-38-542-JC-VN
	φ 48.6	ARI-48-542-JB-VN
Size 75 * ¹ □□	φ 38	ARI-38-692-JC-VN
	φ 48.6	ARI-48-692-JB-VN
Size 90 * ¹ □□	φ 38	ARI-38-842-JC-VN
	φ 48.6	ARI-48-842-JB-VN

* 1 Indicates size (L direction) for the model of this product
Example) F-RAT-NX75-F60-7550-EN-S3

Driver card

Driver cards are common with each size of the F-RAT.

M1 : For carrier wheel transfer M2 : For roller transfer	IB-E04F-□-FT
M3 : For drive switching	HBM-201B□

* Specify □ = N (NPN signal input/output) / P (PNP signal input/output).

10. Maintenance/Inspection

10-4. Replacement of roller transfer MDR/idlers /roller drive belts

Before replacement

If any abnormalities are found in one of the roller transfer MDR, idlers, and/or roller drive belts, replace them according to the following methods.

- 1 Before replacement, prepare necessary tools.

Tools to be used

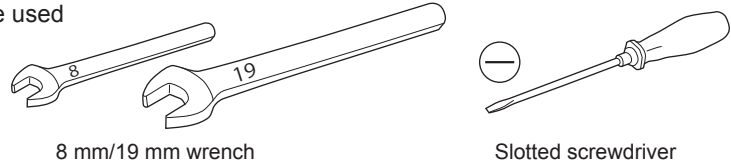

- 2 Turn off the power of all connecting devices.



- Shut off the power switch, leave for three minutes or more, and discharge electricity inside the DC power supply equipment.
- Wear protective equipment, such as gloves.

Replacement procedures

Removing roller transfer MDR/idlers/roller drive belts

Remove the hold cover

- 1 Remove the screws at the four positions, and remove the hold cover from the F-RAT main unit.

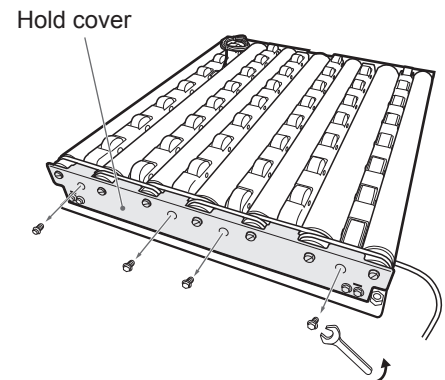

Remove idlers

Remove idlers in order, from the edge of the module, to the position where the roller transfer MDR, idler, or roller drive belt to be replaced can be removed.

- 1 Push deeper the spring loaded shaft of the idler using the tip of a slotted screwdriver, etc.

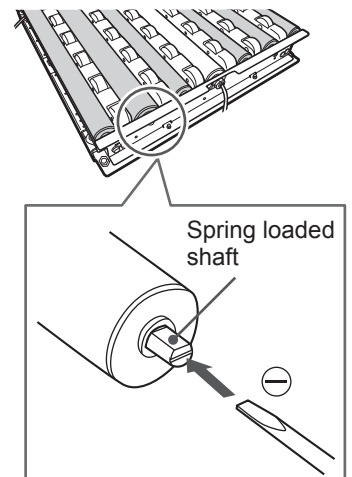

10. Maintenance/Inspection

Replacement procedures

- 2 Slide the spring loaded shaft from the fixed hole (1), and remove the idler from the frame (2)

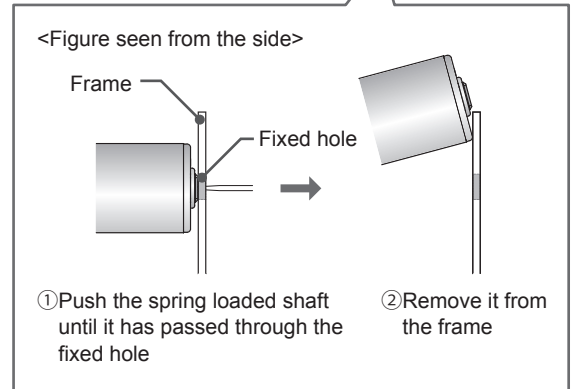
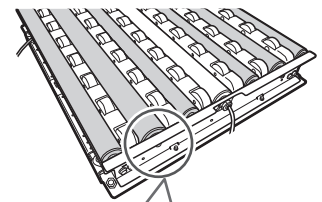

- 3 Remove the roller drive belt, and remove the idler



■ The roller drive belt can be removed easily by pulling it while turning the idler.

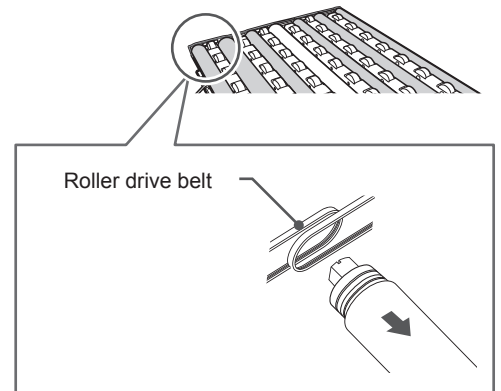

Remove other idlers in the same procedures.

Remove the roller transfer MDR

- 1 Remove the cable tie securing the power cable (1), and remove the hex.nut M12 / toothed washer from the power cable (2)

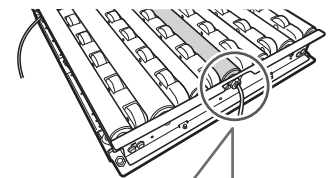

■ When removing the hex.nut M12 / toothed washer, be careful not to damage the cable.

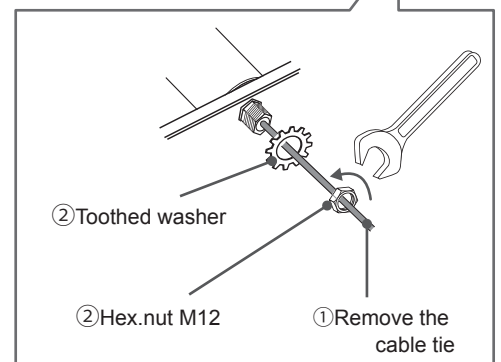

10. Maintenance/Inspection

Replacement procedures

- 2 Lift up the tip of the roller transfer MDR (①), and remove the roller drive belt. (②) Remove the roller transfer MDR (③), and pull the power cable off the fixed hole on the frame (④)

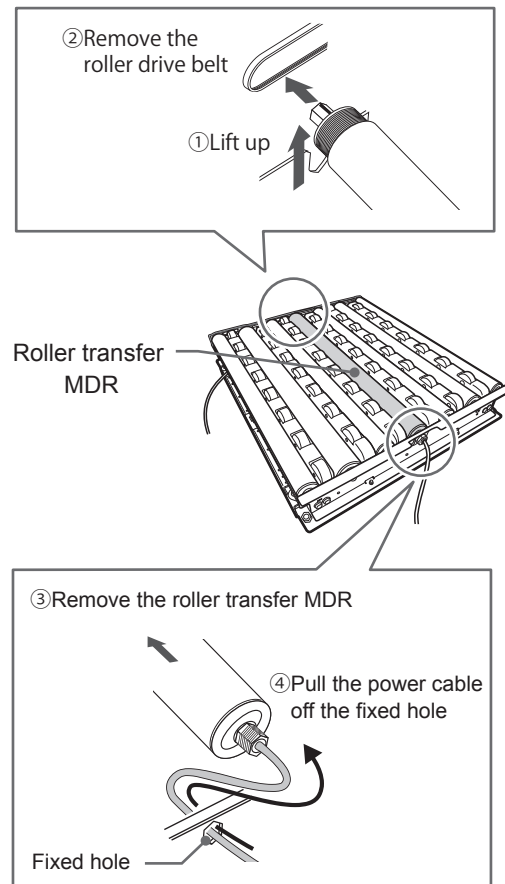

Mounting roller transfer MDR/idlers/roller drive belts

Mount the roller transfer MDR

- 1 Pass the roller transfer MDR power cable through the fixed hole on the frame (①), and put the attaching shaft into the hole (②)

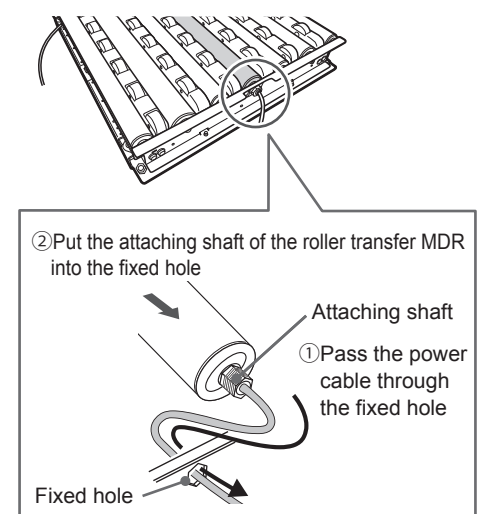

10. Maintenance/Inspection

Replacement procedures

- 2 Mount the roller drive belt on the V-ribbed pulley of the roller transfer MDR (1), align the tip of the attaching shaft with the notch shape, and fit it into the frame (2)

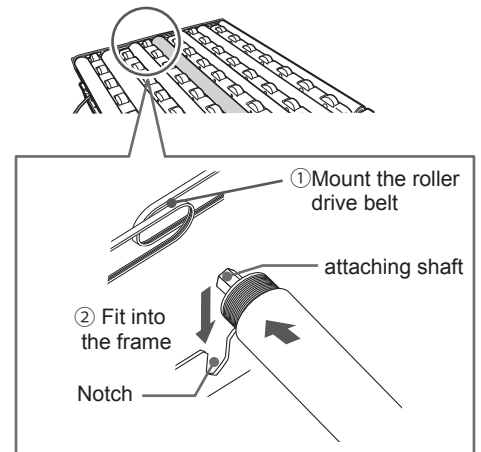
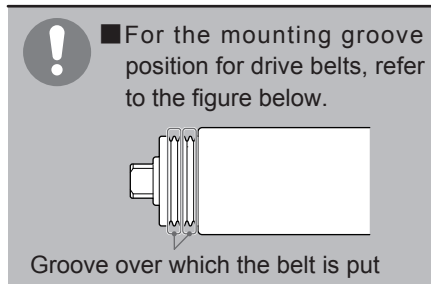

- 3 Fix the hex.nut M12 / toothed washer (1), and bind the power cable with the cable tie (2)

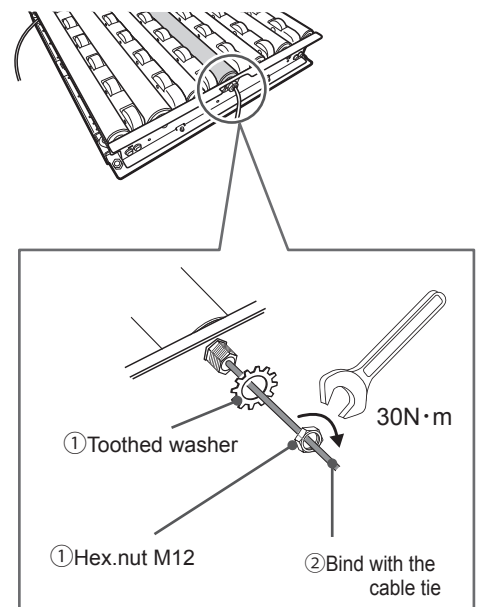
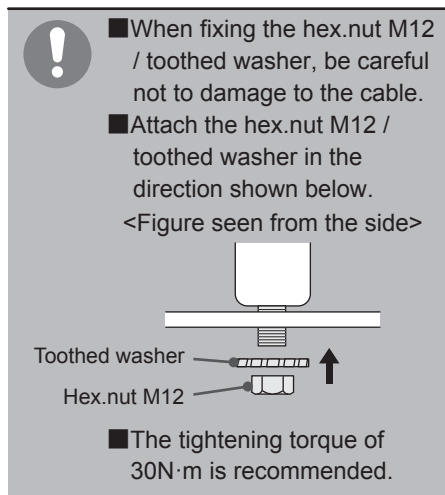

Mount the idler

- 1 Mount the roller drive belt on the V-ribbed pulley on the idler

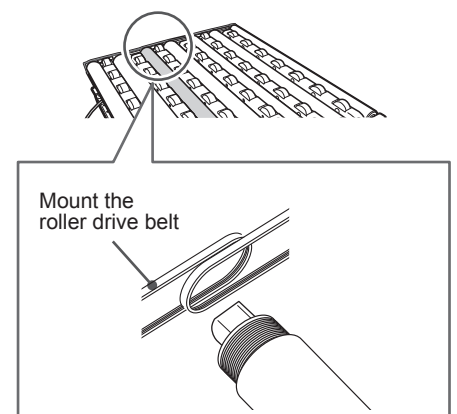
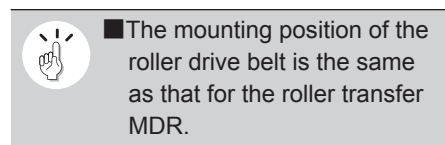

Safety precautions

Advance preparation

Product check

Structures

Installation/Wiring

IB-E04F-FT settings

Control/Operation

Maintenance/Inspection

Troubleshooting

Appendix

10. Maintenance/Inspection

Replacement procedures

- Align the tip of the attaching shaft on the side of the belt on the V-ribbed pulley, where the roller drive belt has been mounted, with the notch shape on the frame, and fit it into the frame

! Press the D-shaped cut surface of the axis onto the plate, and fit it into the frame.

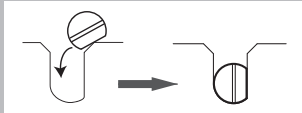

! Check that the attaching shaft has come out of the external side of the frame, as shown in the figure below.

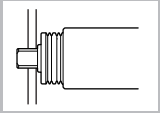
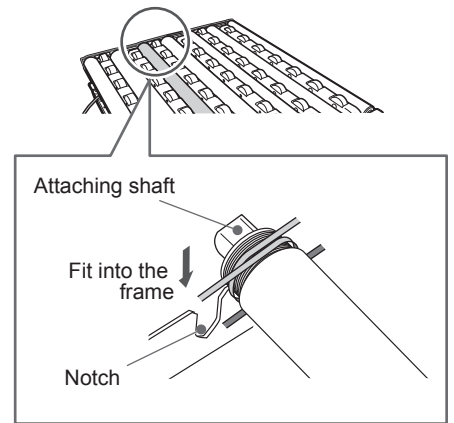
- Push the spring loaded shaft of the idler by the tip of a slotted screwdriver, etc. (1), and pass it through the fixed hole (2)

! Check that the spring loaded shaft has sufficiently come out of the external side of the frame, as shown in the figure below.

Mount the hold cover

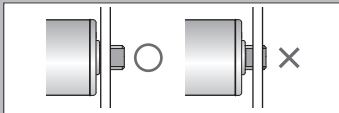
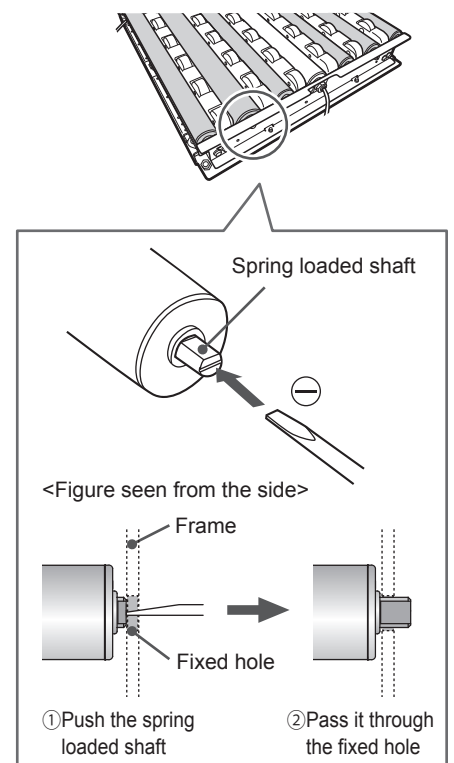
- Mount the hold cover in the reverse of the procedures on page 77, "Remove the hold cover".

! Make sure to mount the hold cover so that the roller drive belt can be seen.

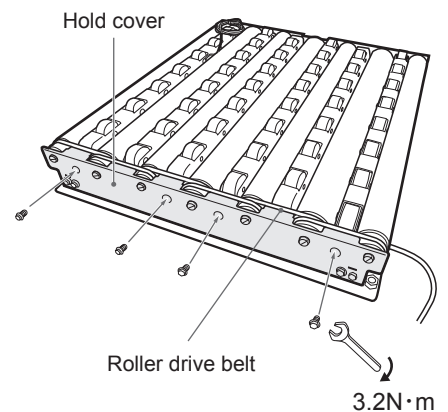

10. Maintenance/Inspection

10-5.
Replacement of the carrier wheel cassette

Before replacement

If any abnormalities are found in the carrier wheels, replace the whole carrier wheel cassette.

1 Before replacement, prepare necessary tools.

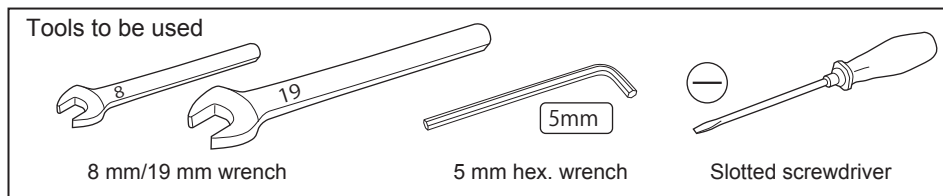

2 Turn off the power of all connecting devices.



- Shut off the power switch, leave for three minutes or more, and discharge electricity inside the DC power supply equipment.
- Wear protective equipment, such as gloves.

Replacement procedure

Removing roller transfer MDR/idlers/roller drive belts

Remove the idlers in order, from the edge of the module to the position where the carrier wheel cassette to be replaced can be removed.

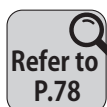

10-4.
Replacement of roller transfer MDR/idlers/roller drive belts

Removing roller transfer MDR/idlers/roller drive belts

Remove the carrier wheel cassette

1 Remove hex. bolts at four positions circled on the carrier wheel cassette to be replaced, and lift up the cassette.



- When removing hex. bolts, be careful not to drop them and/or the hex. wrench on the lower part of the F-RAT.

Example) For size 7550

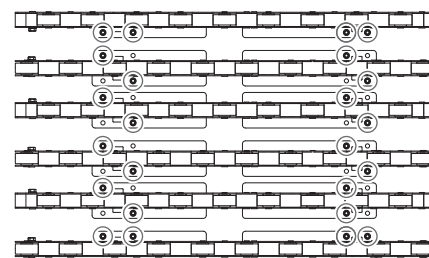

Carrier wheel cassette

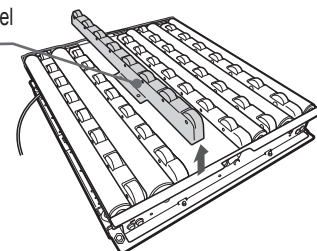

10. Maintenance/Inspection

Replacement procedures

Mounting the carrier wheel cassette on the F-RAT main unit

- 1 Check the model of the removed carrier wheel cassette and replacement carrier wheel cassette.



Indication example)

NX-75CC-75A-HD1

This part of the carrier wheel cassette is indicated on the product.

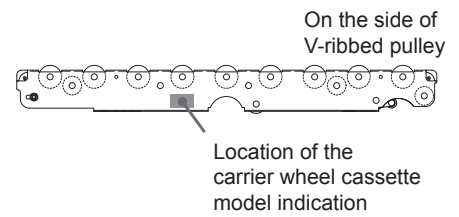

- 2 Mount the replacement carrier wheel cassette with hex. bolts at four positions circled in the figure, and secure it.



The tightening torque of 11 N·m is recommended. Excessive tightening may result in damage to hex. bolts.

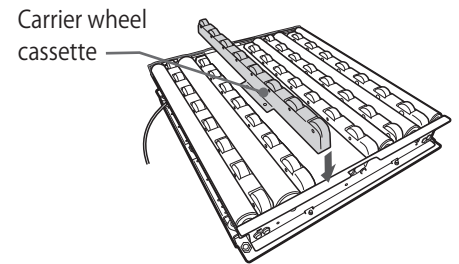
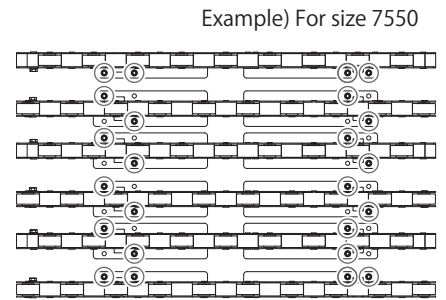

Mounting roller transfer MDR/idlers/roller drive belts

Mount the roller transfer MDR, idlers, and/or roller drive belt that have been removed.



10-4.

Replacement of roller transfer MDR/idlers/roller drive belts

Mounting roller transfer MDR/idlers/roller drive belts

11. Troubleshooting

11. Troubleshooting

If you believe the product may be malfunctioning, check the contents described in this section before contacting the supplier and/or asking for repair.

Symptoms

F-RAT does not operate

Items to be checked	Countermeasures	References
Is PWR LED (Green) for each driver card ON? Or, has 24 VDC been supplied in the power connector part of driver cards?	Supply 24V DC.	7. Installation/ Wiring (⇒P.25)
Is ERR LED (Red) for each driver card blinking, or is it ON and is there an error output?	Remove the cause of error, and release the error.	10. Maintenance/ inspection (⇒P.69)
Has each connector been connected correctly? Has wiring been performed properly?	Check wiring, and perform wiring properly if it has not already been done so.	7. Installation/ Wiring (⇒P.25)
Has each driver card and sensor type* (NPN input/output / PNP input/output) matched the input and output signal type based on the IB-E04F-FT wiring? * Check the model of driver cards and sensors.	Match each driver card and sensor type (NPN input/output / PNP input/output) with the input and output signal type on IB-E04F-FT	7. Installation/ Wiring (⇒P.25)
Has the same voltage to be input as the power supply voltage been used?	Use the same voltage to be input as the power supply voltage.	7. Installation/ Wiring (⇒P.25)

The transfer surface cannot be switched, or transfer surface switching operation is incorrect

Items to be checked	Countermeasures	References
Has the initial setting (teaching setting) been performed?	Perform the initial setting (teaching setting).	Initial setting (Teaching setting) (⇒P.65)
Is ERR LED (Red) on the driver card for M3: drive switching blinking, or is it ON and is there an error output?	Remove the cause of error, and release the error.	10. Maintenance/ inspection (⇒P.69)
Has the switching signal input to the driver card for M3: drive switching corresponded to the transfer surface? Also, is the input timing correct?	Check the signal input and input timing when the transfer surface is switched.	9. Control/ Operation Transfer flow chart (⇒P.64)
Has the setting of the driver card for M3: drive switching not been changed?	Check the setting of the driver card for M3: drive switching switch.	7. Installation/ Wiring (⇒P.42)

11. Troubleshooting

Symptoms

When loading, trays get stuck, or cannot be transferred

Items to be checked	Countermeasures	References
Is the load conveyor level the same as the level of the F-RAT?	Align levels of the load conveyor and the F-RAT.	7. Installation/Wiring (⇒P.25)
When loading by carrier wheels, have they been set on the top of the surface? When loading by rollers, have they been set on the top of the surface?	Set either carrier wheels or rollers on the top of the surface according to the loading direction.	8. Control/Operation (⇒P.52)
When loading by carrier wheels, have you run the carrier wheel MDR (M1)? When loading by rollers, have you run the roller MDR (M2)? Also, have you run the MDR until loading ends?	Run either carrier wheel MDR (M1) or roller MDR (M2) according to the loading direction until transfer ends.	8. Control/Operation (⇒P.52)
When loading by carrier wheels, are there any carrier wheels rotating slower than others?	Replace the carrier wheel cassette including the slow rotating wheels.	9. Maintenance/inspection (⇒P.69)
Has the transfer drive switching MDR (M3) not run at the time of loading?	Do not run the drive switching MDR (M3) until transfer ends.	8. Control/Operation (⇒P.52)

When discharging, trays get stuck, or cannot be transferred

Items to be checked	Countermeasures	References
Is the discharge conveyor level same as the level of the F-RAT?	Align levels of the discharge conveyor and the F-RAT.	7. Installation/Wiring (⇒P.25)
When discharging by carrier wheels, have they been set on the top of the surface? When discharging by rollers, have they been set on the top of the surface?	Set either carrier wheels or rollers on the top of the surface according to the discharging direction.	9. Control/Operation (⇒P.52)
When discharging by carrier wheels, have you run the carrier wheel MDR (M1)? When discharging by rollers, have you run the roller MDR (M2)? Also, have you run the MDR until discharging ends?	Run either carrier wheel MDR (M1) or roller MDR (M2) according to the discharging direction until discharging ends.	9. Control/Operation (⇒P.52)
When discharging by carrier wheels, are there any carrier wheels rotating slower than others?	Replace the carrier wheel cassette including the slow rotating wheels.	10. Maintenance/inspection (⇒P.69)
Has the transfer drive switching MDR (M3) not run at the time of discharging?	Do not run the drive switching MDR (M3) until discharging ends.	9. Control/Operation (⇒P.52)

11. Troubleshooting

Symptoms

- The speed cannot be changed
- The speed setting is incorrect

Items to be checked	Countermeasures	References
Is MA used to change the carrier wheel speed, and MB used to change the roller speed?	Use MA to change the carrier wheel speed, and use MB to change the roller speed.	Changing the speed (⇒P.58)

The transfer direction (rotating direction of carrier wheels/rollers) is incorrect

Items to be checked	Countermeasures	References
Is the transfer/diverting direction based on the rotating direction settings for the driver card for M1: carrier wheels/M2: rollers?	Set the correct transfer/diverting direction, and the correct the rotating direction for the driver card for M1: carrier wheels/ M2: rollers.	9 Control/ Operation (⇒P.52)

Appendix

Appendix

Appendix 1.
Product specifications

F-RAT main unit specifications

Size 60 □ □

		6040	6050	6060	6070	6080
F-RAT main unit	Total length (L) Carrier wheel transfer direction	595mm				
	Total width (W) Roller transfer direction	395mm	495mm	595mm	695mm	795mm
	Weight	32kg	38kg	44kg	52kg	60kg
Maximum load weight		50kg				

Size 75 □ □

		7540	7550	7560	7570	7580
F-RAT main unit	Total length (L) Carrier wheel transfer direction	745mm				
	Total width (W) Roller transfer direction	395mm	495mm	595mm	695mm	795mm
	Weight	42kg	48kg	54kg	63kg	71kg
Maximum load weight		50kg				

Size 90 □ □

		9040	9050	9060	9070	9080
F-RAT main unit	Total length (L) Carrier wheel transfer direction	895mm				
	Total width (W) Roller transfer direction	395mm	495mm	595mm	695mm	795mm
	Weight	52kg	58kg	64kg	74kg	82kg
Maximum load weight		50kg				

* Values of the maximum load weight are reference only since they may change depending on tray conditions. Depending on the bottom shape of trays, they may not be transferred normally, even if they are within the above size range.

Common

Material	Frame	Galvanized iron
	Carrier wheel	Urethane
	Roller	STKM
Speed**	Carrier wheel	7.7 ~ 66.7m/min
	Roller	2.1 ~ 18.3m/min (PM486FE-17 type)
		7.5 ~ 65.0m/min (PM486FE-60 type)
Transfer surface switching time		0.6s

**Values indicate the speed when trays are not placed on carrier wheels and rollers.



- During operation, the rising time to the setting speed may vary depending on ambient temperature. Perform running operation thoroughly.
- Values described above may differ from the actual transfer speed depending on the weight, material, bottom surface, and/or shape of trays, as well as ambient temperature.

Installation environment	Ambient temperature	0 to 40°C (no freezing)
	Ambient humidity	90%RH or less (no condensation)
	Altitude	1,000 m or less
	Atmosphere	No corrosive gas
	Vibration	0.5G or less
	Location	Indoor
	Mounting surface tilt (inclination)	0.5% or less
Pollution degree		2 (according to the definition of IEC60640-1, UL840)

Product label

FLAT RIGHT ANGLE TRANSFER

F-RAT-NX75-F60-7540-CN-S3

RATED INPUT: DC24V / 4.9A

RATED POWER: 56W

PAYLOAD: max 50 kg

SERIAL No:

MFG. YEAR: DOC:

Product model

Safety precautions

Advance preparation

Product check

Structures

Installation/Wiring

IB-E04F-FT settings

Control/Operation

Maintenance/Inspection

Troubleshooting

Appendix

Appendix

Appendix 1.
Product specifications

Driver card specifications

		For carrier wheel transfer / roller transfer	For drive switching
Model		IB-E04F-□-FT (□=N : NPN, P : PNP)	HBM-201B□ (□=N : NPN, P : PNP)
Power supply voltage		24V DC±10%	24V DC±10%
Rated voltage		24V DC	24V DC
Static current		0.5A	0.06A
Starting current		Motor A : 7.0A / Motor B : 4.0A	4.0A
Peak current		30A(1msec or less)	20A(1msec or less)
Wire diameter (Applicable wires to connectors included as standard)	Power connector (CN1)	1.25 ~ 2.5mm ² (AWG : 16 ~ 12)	0.50 ~ 1.5mm ² (AWG : 20 ~ 14)
	Control connector (CN2)	0.08 ~ 0.5mm ² (AWG : 28 ~ 20)	0.08 ~ 0.5mm ² (AWG : 28 ~ 20)
Thermal protection		Driver card: 95°C Motor: 105°C	Driver card: 85°C Motor: 110°C
Operating environment	Ambient temperature	0 to 40°C (no freezing)	0 to 40°C (no freezing)
	Ambient humidity	90%RH or less (no condensation)	90%RH or less (no condensation)
	Atmosphere	No corrosive gas	No corrosive gas
	Vibration	0.5G or less	0.5G or less
	Installation location	Indoor	Indoor
Time from RUN signal input to motor starting		15 msec or less	—

Transfer throughput

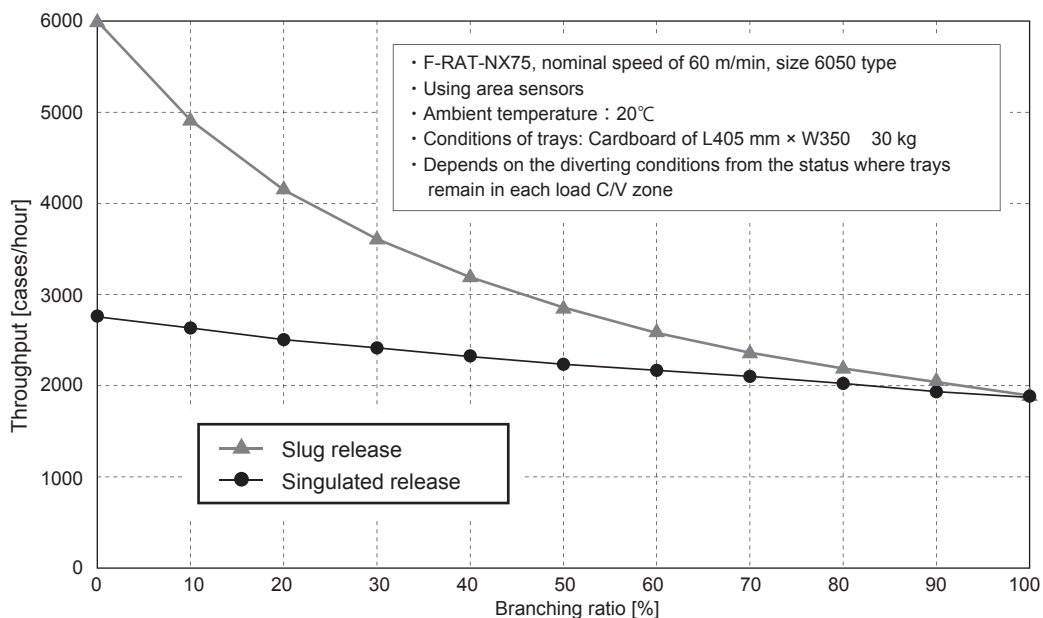

- * Values on the graph are only references based on our measurement and are not guaranteed.
- * For simultaneous transfer, indicated values are obtained when C/Vs before and behind the F-RAT have been controlled optimally.
- * The stopping distance of trays and throughput depends on the size, material, bottom status of trays, ambient temperature, and/or the speed.

Safety precautions

Advance preparation

Product check

Structures

Installation/Wiring

IB-E04F-FT settings

Control/Operation

Maintenance/Inspection

Troubleshooting

Appendix

Appendix

Appendix 2.
Replacement parts/Options

Replacement parts



Do not store carrier wheel cassettes in places subject to high temperature, high humidity, and/or direct sunlight. Failure to follow this could result in its lifetime to be significantly shortened.

Part name		Part number	
1	Carrier wheel cassette	Size 60 *1 □□	NX75-CC60○-HD1
		Size 75 *1 □□	NX75-CC75○-HD1
		Size 90 *1 □□	NX75-CC90○-HD1
○: Indicates a type of the cassette. For details, refer to P.76.			
2	Roller drive belt (V-ribbed pulley)	2PJ-265	
		2PJ-246 * Only for belts, size □□60 *2 type, which are used to link Φ38 idlers.	
3	Roller transfer MDR	Size 60 *1 □□	PM486FE-(17/60) *3 -542-D-024-JA-Z150-VN
		Size 75 *1 □□	PM486FE-(17/60) *3 -692-D-024-JA-Z150-VN
		Size 90 *1 □□	PM486FE-(17/60) *3 -842-D-024-JA-Z150-VN
4	Idler	Size 60 *1 □□	φ 38 ARI-38-542-JC-VN
			φ 48.6 ARI-48-542-JB-VN
		Size 75 *1 □□	φ 38 ARI-38-692-JC-VN
			φ 48.6 ARI-48-692-JB-VN
		Size 90 *1 □□	φ 38 ARI-38-842-JC-VN
			φ 48.6 ARI-48-842-JB-VN
5	Driver card □: Specify the N=NPN/P=PNP type based on the input and output type.	IB-E04F-□-FT	(for carrier wheel transfer MDR)
			(for roller transfer MDR)
		HBM-201B□	(for drive switching MDR)

* 1 Indicates size (L direction) for the model of this product. ----- Example) F-RAT-NX75-F60-7550-EN-S3

* 2 Indicates size (W direction) for the model of this product. ----- Example) F-RAT-NX75-F60-7560-EN-S3

* 3 Indicates the nominal speed for the model of this product. Example) F-RAT-NX75-F60-7550-EN-S3

Options

Extension cable

■ 12P extension cable : F-RAT [M1 / M2] — IB-E04F-FT [MA]

Model	12P extension cable length
ACE-CBM-G0600	L= 600mm
ACE-CBM-G1200	L=1200mm

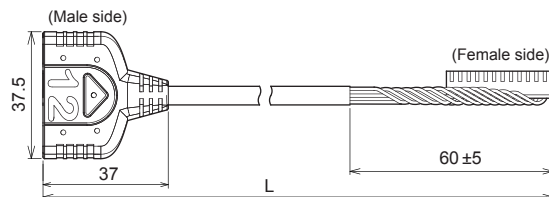

■ 10P extension cable : F-RAT [M3] — HBM-201

Model	10P extension cable length
ACE-CBM-A0600	L= 600mm
ACE-CBM-A0850	L= 850mm
ACE-CBM-A1200	L=1200mm

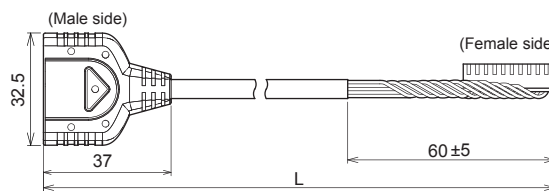

Conversion cable

■ 10P/12P conversion cable : F-RAT [M2] — IB-E04F-FT [MB]

Model	10P/12P conversion cable length
ACT-IBE-C0300	L= 300mm

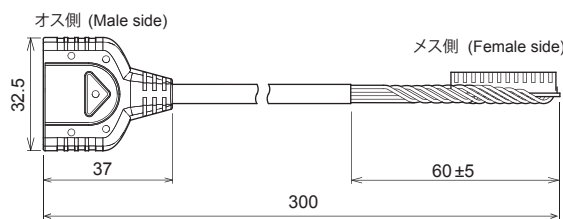

Safety precautions

Advance preparation

Product check

Structures

Installation/Wiring

IB-E04F-FT settings

Control/Operation

Maintenance/Inspection

Troubleshooting

Appendix

Appendix

Stay
(with hex. bolt/plain washer/
spring washer)

Size	L	X	(mm)
6040 / 7540 / 9040	370	400	
6050 / 7550 / 9050	470	500	
6060 / 7560 / 9060	570	600	
6070 / 7570 / 9070	670	700	
6080 / 7580 / 9080	770	800	

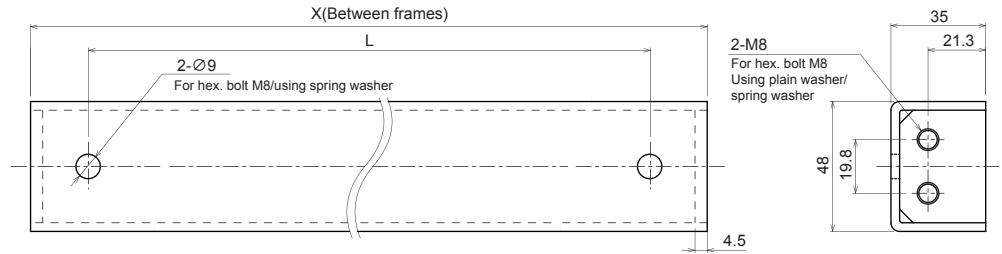

* For X dimensions (between frames) other than those mentioned above, contact us.

Appendix

Appendix 3.
Residual risk list/MAP

[Seriousness of harm]

WARNING: Indicates that there is a possibility that severe injury or even death may result if protective measures have not been taken

CAUTION: Indicates that there is a possibility that minor injury may result if protective measures have not been taken

Residual risk list

No.	Operation stage	Work	Qualifications/ education required for work	Locations on machine	Seriousness of harm	Remaining risk factors	Examples of assumed measures	Measures that have been taken independently	Reference page
1	Installation	Unpack/ Carry	Having carefully read the user manual, and having full knowledge of all the contents	Metal parts on the product	CAUTION	Hands may get injured by metal parts of the product	Wear protective equipment, such as gloves, when working.	Described in the instruction manual	10
2	Installation	Carry		No particular location	CAUTION	Carrying the heavy load alone may result in damage to the main machine unit, and/or injury to the body	Have more than one person hold and support the bottom when carrying.	Described in the instruction manual	10
3	Installation	Carry/ Install		No particular location	CAUTION	Dropping the product or letting it fall when carrying and/or installing may result in damage to the main machine unit, and/or injury to the body	Check safety of installation location in advance, and wear protective equipment, such as protective glasses, footwear, and/or gloves, when working	Described in the instruction manual	10
4	Installation	Install		Bottom of the product	CAUTION	Fingers may get stuck and workers may be injured when securing the main unit on the stay	When putting the main unit on the stay, hold the very bottom of the main unit, and prevent fingers from getting stuck	Described in the instruction manual	35
5	Operation	Trial run		No particular location	CAUTION	At the trial run by the single unit, trays may flow to this product	Stop the surrounding conveyor operation before starting operation	Described in the instruction manual	68
6	Operation	All during operation		Gaps between the moving parts, or moving and fixed parts	WARNING	Workers' fingers and/or hands may get stuck in gaps between the moving parts, or moving and fixed parts of the main unit	Do not touch this product during operation	<ul style="list-style-type: none"> Posting of warning and caution labels Described in the instruction manual 	8
7	Operation	All during operation		Top panel of the product	CAUTION	Workers may step on the main unit and lose their footing, or may fall when the main unit moves	Keep workers informed thoroughly about the prohibition of stepping on the machine	Described in the instruction manual	8
8	Operation	All during operation		No particular location	CAUTION	If problems occur, trays may collide with each other, and pop out of the equipment	For example, mount guide rails on the conveyor frames, and prevent trays from popping.	Described in the instruction manual	11
9	During maintenance/ inspection	All during maintenance/ inspection		Power supply part to the product (driver card)	WARNING	Persons turning on the power without notice may result in unexpected operation of the product, and/or injury of workers	Post warning labels so as to prevent unauthorized persons from turning on the power	Described in the instruction manual	12
10	During maintenance/ inspection	All during maintenance/ inspection		No particular location	WARNING	Workers' fingers and/or hands may get stuck in the product, and injured	<ul style="list-style-type: none"> Wear protective equipment, such as protective glasses, footwear, and/or gloves Do not put hands close to rotating parts. Take off gloves when workers need to get your hands close to rotating parts during operation. 	Described in the instruction manual	13

Residual risk MAP

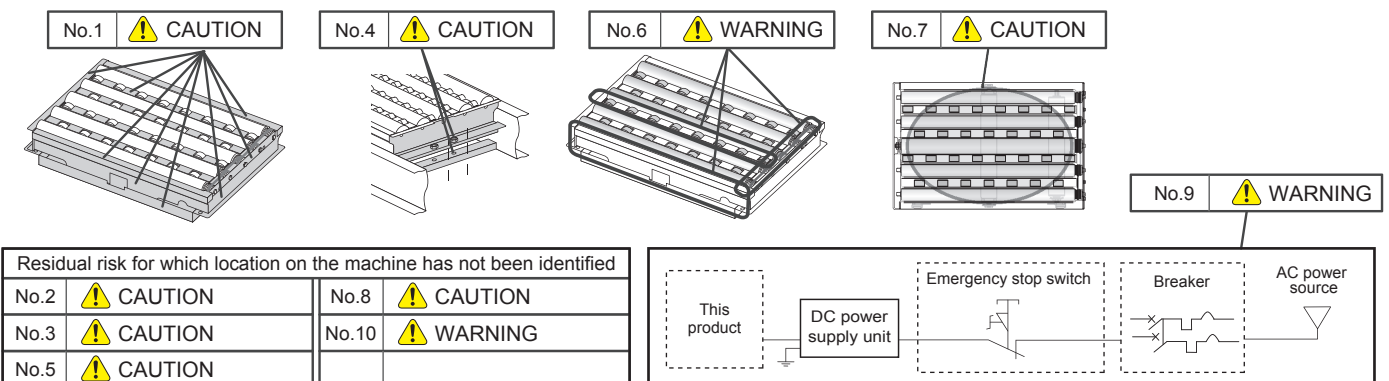

Technology for tomorrow



ITOH DENKI CO.,LTD.

Global Headquarters

■ ITOH DENKI CO., LTD.

1146-2 Asazuma-cho, Kasai, Hyogo 679-0105 Japan
Tel: +81 790 47 0955 Fax: +81 790 47 1325
www.itohdenki.co.jp

Europe, Middle East, Africa

■ ITOH DENKI EUROPE SAS

490, Avenue des Jourdiés – P.A.E. les Jourdiés
74800 Saint Pierre en Faucigny, France
Tel: +33 4 50 03 09 99 Fax: +33 4 50 03 07 60
www.itoh-denki.com

North & South Americas

■ ITOH DENKI USA, INC

2 Great Valley Blvd., Wilkes-Barre, PA 18706-5332 U.S.A.
Tel: +1 570 820 8811 Fax: +1 570 820 8838
www.itohdenki.com

Mainland China

■ ITOH DENKI SHANGHAI CO., LTD.

Room 1812, No.689, Guangdong Rd., Huangpu district,
Shanghai 200001, P.R. China
Tel: +86 21 6341 0181 Fax: +86 21 6341 0180
www.itohdenki.com.cn

<https://www.itohdenki.co.jp>

Specifications or appearance of product are subject to change without prior notice.

Ver. 8.0